

KL-3022

Technical Documentation 2-Channel Analog Input Terminal 4 – 20mA

Please keep for further use !

Edition date/Rev. date: 23.03.1998
Document no./Rev. no.: TRS - V - BA - GB - 0108 - 00
Software version: 1.0
File name: TRS-V-BA-GB-0108.DOC
Author: KOH

TRSystemtechnik GmbH
Eglisshalde 6
D-78647 Trossingen
Germany
Tel. +49 - (0) 7425 / 228-0
Fax +49 - (0) 7425 / 228-34

Imprint

TRSystemtechnik GmbH

D-78647 Trossingen
Eglisshalde 6
Tel.: (+49) 07425/228-0
Fax: (+49) 07425/228-34

© Copyright 1998 TRSystemtechnik

Guarantee

In our ongoing efforts to improve our products, TRSystemtechnik reserve the right to alter the information contained in this document without prior notice.

Printing

This manual was edited using text formatting software on a DOS personal computer. The text was printed in *Arial*.

Fonts

Italics and **bold** type are used for the title of a document or to emphasize text passages.

Passages written in *Courier* show text which is visible on the display as well as software menu selections.

"< >" refers to keys on your computer keyboard (e.g. <RETURN>).

Note

Text following the "NOTE" symbol describes important features of the respective product.

Copyright Information ©

MS-DOS is a registered trademark of Microsoft Corporation.

Revision History

i

Note:

The cover of this document shows the current revision status and the corresponding date. Since each individual page has its own revision status and date in the footer, there may be different revision statuses within the document.

Document created:

23.03.1998

Revision	Date

Table of contents

2-Channel 4 to 20 mA Analog Input Terminal KL3022	5
Technical Data.....	5
Description of functions.....	6
Terminal configuration	7
Register communication KL3022.....	9
Annex	17

2-Channel 4 to 20 mA Analog Input Terminal KL3022

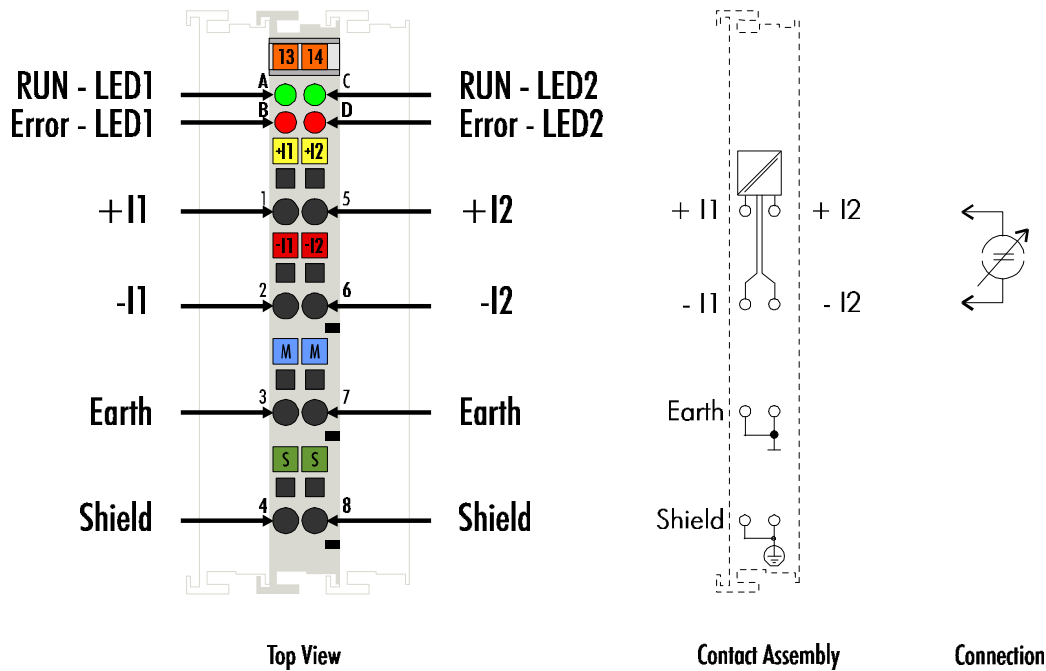

Technical Data	KL3022
Number of inputs	2
Power supply	via the K-Bus
Signal current	0 ... 20 mA
Internal resistance	50 Ω typ.
Common mode voltage UCM	35 V
Resolution	12 bits
Total conversion time	~ 2 ms
Electrical isolation	500 V rms (K-bus / signal voltage)
Current consumption	60 mA typ.
Bit width in the process image	I: 2 x 16 bits, (2 x 8 bits control/status can be optionally inserted)
Configuration	no address or configuration setting
Weight approximately	70 g
Operating temperature	0°C ... +55°C
Storage temperature	-25°C ... +85°C
Relative humidity	95% no condensation
Vibration/shock resistance	In accordance with IEC 68-2-6 / IEC 68-2-27
EMC resistance burst/ESD	In accordance with EN 61000-4-4 / EN 61000-4-2 Limits to EN 50082-2
Installation position	any
Degree of protection	IP20

Description of functions

The analog input terminal KL3022 processes signals within the range from 0 – 20 mA with a resolution of 12 bits (4096 increments). The inputs of the KL3022 are differential inputs which share a common earth. As a result the KL3022 is ideally suited to measuring earth free current loops. A voltage difference at the inputs, due to cross voltages, of up to 35 V result in a negligible inconsistency in the measured value of the inputs.

Output format of process data

In the default setting, process data is represented in the two's complement (-1 corresponds to 0xFFFF). By way of the feature register, other modes of representation can be selected (e.g. signed amount representation, Siemens output format).

Measured value	Decimal output	Hexadecimal output
4mA	0	0x0000
12mA	16383	0x3FFF
20mA	32767	0x7FFF

LED display

The four RUN LEDs indicate the operating state of the affiliated terminal channel.

green LEDs: RUN:

On – normal operation

Off – a watchdog-timer overflow has occurred. The green LEDs go off if no process data is transferred by the bus coupler for 100 ms.

red LEDs: ERROR

On – The end stop of the ADC-converter is reached. The current is higher than 21.5 mA.

Off – normal operation

Process data

The process data that is transferred to the bus coupler is calculated on the basis of the following equations:

X_adc: AD converter output values
 Y_au : Process data to the PLC
 B_a,A_a : Manufacturer gain and offset adjustment (R17,R18)
 B_h,A_h : Manufacturer scaling (R19,R20)
 B_w,A_w : User scaling (R33,R34)

a) neither user nor manufacturer scaling active:

$$Y_a = (B_a + X_{adc}) * A_a \quad (1.0)$$

$$Y_{aus} = Y_a$$

b) Manufacturer scaling active: (default)

$$Y_1 = B_h + A_h * Y_a \quad (1.1)$$

$$Y_{aus} = Y_1$$

c) User scaling active:
 $Y_2 = B_w + A_w * Y_a$ (1.2)
 $Y_{aus} = Y_2$

d) Manufacturer and user scaling active:
 $Y_1 = B_h + A_h * Y_a$ (1.3)
 $Y_2 = B_w + A_w * Y_1$ (1.4)
 $Y_{aus} = Y_2$

The straight-line equations are activated by means of R32.

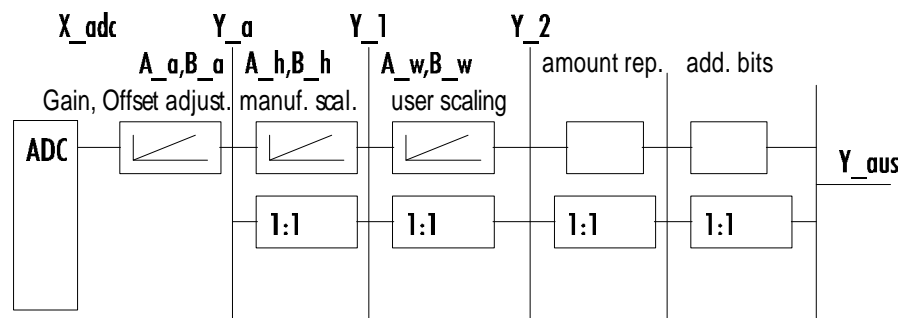

Terminal configuration

The terminal can be configured and parametrized by way of the internal register structure.

Each terminal channel is mapped in the bus coupler. The terminal's data is mapped differently in the bus coupler's memory depending on the type of the bus coupler and on the set mapping configuration (eg. Motorola / Intel format, word alignment,...). For parametrization of a terminal, the control /status byte must also be mapped.

TRS Lightbus
 Coupler BK2000

In the case of the TRS Lightbus coupler BK2000, the control /status byte is always mapped besides the data bytes. It is always in the low byte at the offset address of the terminal channel.

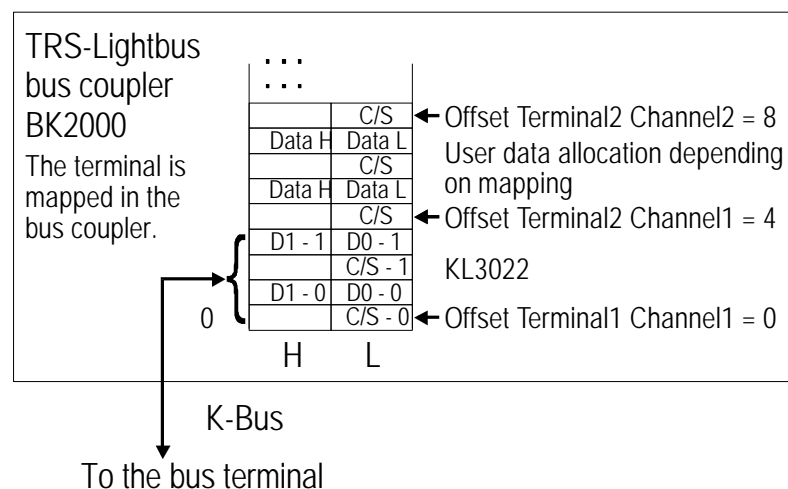

Profibus Coupler BK3000

In the case of the Profibus coupler BK3000, for which terminal channels the control /status byte is also to be inserted must be defined in the master configuration .If the control /status byte is not evaluated, the KL3022 occupies 4 bytes of input data (2 bytes of user data per channel).

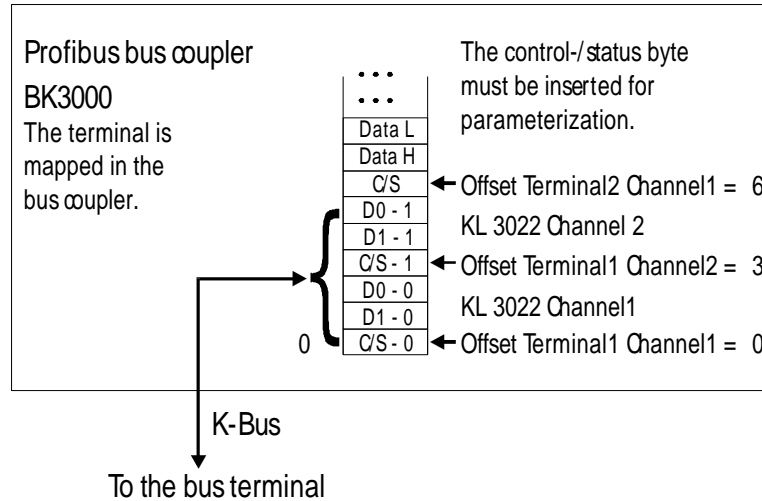

Interbus Coupler BK4000

By default, the Interbus coupler BK4000 maps the KL3022 with 4 bytes of input data (2 bytes of user data per channel). Parametrization via the field bus is not possible. The KS2000 software is required for configuration if use is to be made of the control /status byte.

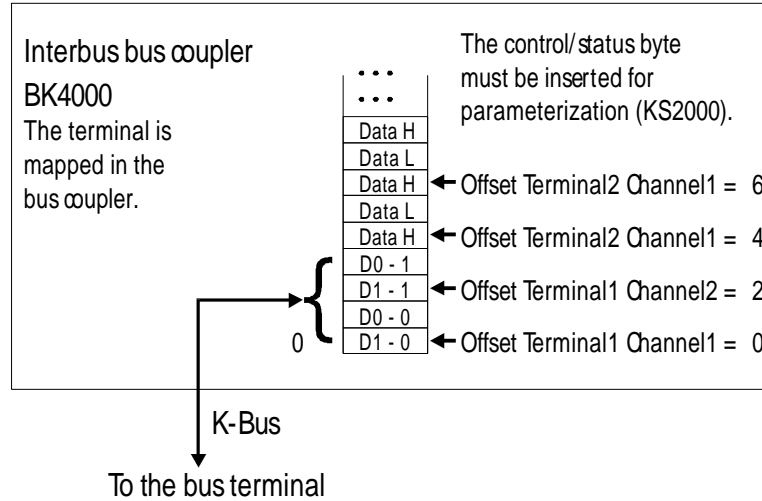

Other bus couplers and further information

You will find further information on the mapping configuration of bus couplers in the annex of the respective bus coupler manual under the heading of "Configuration of masters".

Reference

The annex contains an overview of the possible mapping configurations depending on the adjustable parameters.

Parametrization with the KS2000 software

Parametrization operations can be carried out independantly of the field bus system using the TRS KS2000 configuration software via the serial configuration interface in the bus coupler.

Register communication KL3022

General register description Complex terminals that possess a processor are capable of bidirectionally exchanging data with the higher-level control system. Below, these terminals are referred to as intelligent bus terminals. They include the analog inputs (0-10V, -10-10V, 0-20mA, 4-20mA), the analog outputs (0-10V, -10-10V, 0-20mA, 4-20mA), serial interface terminals (RS485, RS232, TTY, data transfer terminals), counter terminals, the encoder interface, the SSI interface, the PWM terminal and all other parametrizable terminals.

Internally, all intelligent terminals possess a data structure that is identical in terms of its essential characteristics. This data area is organized in words and embraces 64 memory locations. The essential data and parameters of the terminal can be read and adjusted by way of this structure. Function calls with corresponding parameters are also possible. Each logical channel of an intelligent terminal has such a structure (therefore, 4-channel analog terminals have 4 register sets).

This structure is broken down into the following areas:
(You will find a list of all registers at the end of this documentation).

Area	Address
Process variables	0-7
Type registers	8-15
Manufacturer parameters	16-31
User parameters	32-47
Extended user area	48-63

Process variables

R0 - R7 Registers in the terminal's internal RAM:

The process variables can be used in addition to the actual process image and their functions are specific to the terminal.

R0 - R5: These registers have a function that depends on the terminal type.

R6: Diagnostic register

The diagnostic register may contain additional diagnostic information. In the case of serial interface terminals, for example, parity errors that have occurred during data transfer are indicated.

R7: Command register

High-Byte_Write = function parameter

Low-Byte_Write = function number

High-Byte_Read = function result

Low-Byte_Read = function number

Type registers

R8 - R15 Registers in the terminal's internal ROM

The type and system parameters are programmed permanently by the manufacturer and can only be read by the user, but cannot be modified.

R8: Terminal type

The terminal type in register R8 is needed to identify the terminal.

R9: Software version X.y

The software version can be read as an ASCII character string.

R10: Data length

R10 contains the number of multiplexed shift registers and their length in bits.

The bus coupler sees this structure.

R11: Signal channels

In comparison with R10, the number of logically existing channels is located here. For example, one physically existing shift register may consist of several signal channels.

R12: Minimum data length

The respective byte contains the minimum data length of a channel to be transferred. The status byte is omitted if the MSB is set.

R13: Data type register

Data type register	
0x00	Terminal without valid data type
0x01	Byte array
0x02	1 byte n bytes structure
0x03	Word array
0x04	1 byte n words structure
0x05	Double word array
0x06	1 byte n double words structure
0x07	1 byte 1 double word structure
0x08	1 byte 1 double word structure
0x11	Byte array with a variable logical channel length
0x12	1 byte n bytes structure with a variable logical channel length (eg 60xx)
0x13	Word array with a variable logical channel length
0x14	1 byte n words structure with a variable logical channel length.
0x15	Double word array with a variable logical channel length
0x16	1 byte n double words structure with a variable logical channel length

R14: not used

R15: Alignment bits (RAM)

The analog terminal is set to a byte limit in the terminal bus with the alignment bits.

Manufacturer Parameters

R16 - R30 is the area of the "Manufacturer Parameters" (SEEROM)

The manufacturer parameters are specific to each terminal type. They are programmed by the manufacturer, but can also be modified from the control system. The manufacturer parameters are stored permanently in a serial EEPROM in the terminal and are therefore not destroyed by power failures.

These registers can only be modified after setting a code word in R31.

User Parameters

R31 - R47 " Application Parameters" area (SEEROM)

The application parameters are specific to each terminal type. They can be modified by the programmer. The application parameters are stored permanently in a serial EEPROM in the terminal and cannot be destroyed by power failures. From software version 2.A, the user area is write-protected by way of a code word.

R31: Code word register in the RAM

The code word 0x1235 must be entered here to enable modification of parameters in the user area. Write protection is set if a different value is entered in this register. When write protection is inactive, the code word is returned during reading of the register. The register contains the value zero when write protection is active.

R32: Feature register

This register defines the operating modes of the terminal. For example, a user-specific scaling can be activated for the Analog I/O's.

R33 - R47

Registers that depend on the terminal type

Extended application area

R47 - R63

These registers have not yet been implemented.

Register access via process data transfer.

bit 7=1: register mode

When bit 7 of the control byte is set, the first two bytes of the user data are not used for process data transfer, but are written into or read out of the terminal's register set.

*bit 6=0: read
bit 6=1: write*

In bit 6 of the control byte, you define whether a register is to be read or written. When bit 6 is not set, a register is read without modification. The value can be taken from the input process image.

When bit 6 is set, the user data is written into a register. The operation is concluded as soon as the status byte in the input process image has assumed the same value as the control byte in the output process image.

bits 0 to 5: address

The address of the register to be addressed is entered in bits 0 to 5 of the control byte.

Control byte in the register mode

MSB

REG=1	W/NR	A5	A4	A3	A2	A1	A0
-------	------	----	----	----	----	----	----

REG = 0 : Process data transfer

REG = 1 : Access to register structure

W/NR = 0 : Read register

W/NR = 1 : Write register

A5..A0 = Register address

A total of 64 registers can be addressed with the addresses A5...A0.

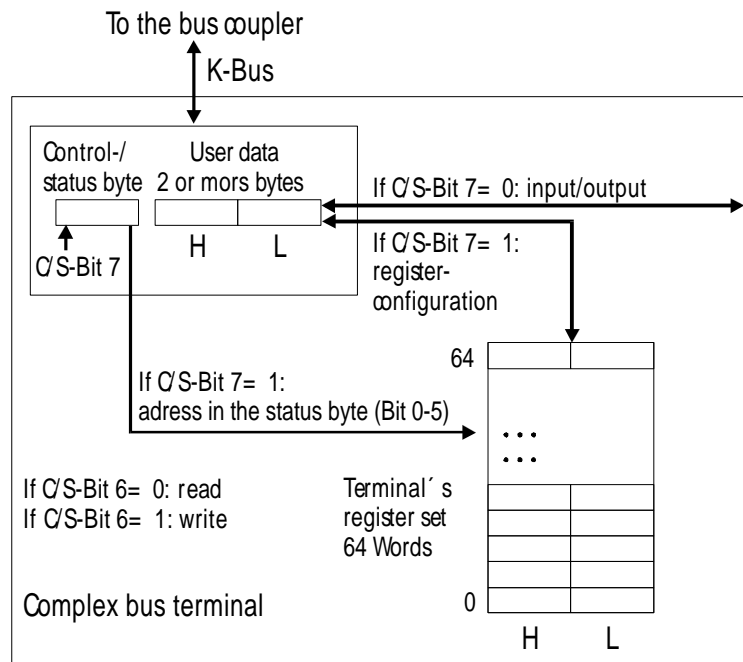

The control or status byte occupies the lowest address of a logical channel. The corresponding register values are located in the following 2 data bytes. (The BK2000 is an exception to this rule: here, an unused data byte is inserted after the control or status byte, thus setting the register value to a word limit.)

Example

Reading register 8 in the BK2000 with a KI3022 and the end terminal.

If the following bytes are transferred from the controller to the terminal,

Byte0	Byte1	Byte2	Byte3
0x88	0xXX	0xXX	0xXX

the terminal returns the following type designation (0xBCE corresponds to the unsigned integer 3022)

Byte0	Byte1	Byte2	Byte3
0x88	0x00	0xCE	0x0B

A further example

Writing register 31 in the BK2000 with an intelligent terminal and the end terminal.

If the following bytes user code word) are transferred from the controller to the terminal),

Byte0	Byte1	Byte2	Byte3
0xDF	0xXX	0x12	0x35

the user code word is set and the terminal returns the register address with the bit 7 for register access as the acknowledgement.

Byte0	Byte1	Byte2	Byte3
0x9F	0x00	0x00	0x00

*Terminal-specific register
description*

Process variables

R0: Raw ADC value X_R

This register contains the raw ADC value.

R1 - R4: No function

R6: Diagnostic register

High byte: not used

Low byte: status byte

Manufacturer's Parameters

R16: Hardware version number

The terminal's hardware version number is stored in this register.

R17: Offset – Hardware B_a

16 bit signed integer

The terminal's offset is adjusted via this register (Eq. 1.1).

Register value approximately 0xFFXX

R18: Gain-Hardware A_a

16 bit * 2⁻¹²

The terminal's gain is adjusted by means of this register (Eq. 1.1).

In doing so a 1 corresponds to 0x1000.

Register value approximately 0x11XX

R19: Manufacturer –Offset B_h

16 bit signed integer [0x0000]

This register contains the offset of the manufacturer's straight-line equation (1.3). The straight-line equation is activated via R32.

R20: Manufacturer scaling A_h

16 bit signed integer *2⁻¹⁰ [0x2002]

This register contains the scaling factor of the manufacturer's straight-line equation (1.3). The straight-line equation is activated via R32.

A 1 corresponds to the register value 0x0400.

R21: Over range limit: OVRL

16 bit signed integer in Y_a GI 1.0 [0x0FFF]

This limit limits the maximum measured range of the input terminal. If it is exceeded, the corresponding status bit is set and the maximum value is output.

R22: Under range limit: UNRL

16 bit signed integer in Y_a GI.1.0 [0x0000]

If the actual value drops below this limit, the corresponding status bit is set and the minimum value is output.

R23: ADC-Hardware preset

[0x0000]

Initialization of the ADC offset register.

Application parameters

R32: Feature register:
[0x1106]

Feature Bit No.		Mode description
Bit 0	1	User scaling (R33, R44) active [0]
Bit 1	1	Manufacturer scaling (R19, R20) active [1]
Bit 2	1	Watchdog timer active [1] By default, the watchdog-timer is on.
Bit 3	1	Signed amount representation [0] The signed amount format is active instead of the 2's complement. (-1 = 0x8001)
Bit 4	1	Siemens output format [0] With this bit, status flags are inserted in the 3 least significant bits (see below).
Bits 7-5	-	not used
Bit 8	1	Over range protection [1] If values exceed or fall below the limits of the registers OVRL (R21), UNRL (R22), the status bits are set accordingly and the measured range is appropriately restricted.
Bit 9	1	Limit 1 active [0] The process data is compared against limit 1 (R35) and corresponding status bits are set.
Bit 10	1	Limit 2 active [0] The process data is compared against limit 1 (R36) and corresponding status bits are set.
Bit 11	1	Filter 1 active[0] The analog input terminal contains the FIR filter of the second order shown further below.
Bit 12	1	Break active [1] Should the maximum current limit of approximately 21,5 mA (the upper limit of the A/D converter) be reached the ring will be disconnected for 100 ms in order to protect the terminal. After which the ring will be closed and a new measurement conversion started. This feature is not supported by the hardware.
Bits 15-13	-	not used

The three least significant bits are used for status evaluation if the Siemens output format is chosen. The process data item is mapped in bits 3-15, and bit 15 is the sign bit. The scaling of the process data in accordance with the Siemens-format must take place over the user scaling (R33, R34)

Measured value	Bits 3-15	Bit 2	Bit 1	Bit 0
		X	ERROR	Overflow
>20 mA		0	0	1
< 20 mA		0	0	0

The following FIR filter of the second order is set with bit 11:

FIR-filter 2. order

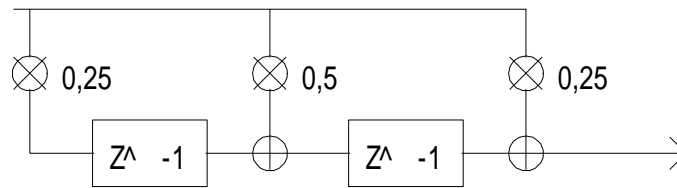

$$A(z) = 0,25 + 0,5 \cdot Z^{-1} + 0,25 \cdot Z^{-2}$$

$$A(j\omega) = 0,5 + 0,5 \cdot \cos(2\pi f)$$

$$F_g = 1/(2\pi) \arccos(\sqrt{2}-1) = 0,182$$

R33: User-Offset B_w

16 bit signed integer

This register contains the offset of the user straight-line equation (1.4). The straight-line equation is activated via R32.

R34: User scaling A_w

16 bit signed integer * 2⁻⁸

This register contains the scaling factor of the user straight-line equation (1.4). The straight-line equation is activated via R32.

R35: Limit 1 in Y_2

If the process data exceeds or falls below this limit, the corresponding bits are set in the status byte.

R36: Limit 2 in Y_2

If the process data exceeds or falls below this limit, the corresponding bits are set in the status byte.

*CONTROL byte
in process data transfer
Gain and offset adjustment*

The control byte is transferred from the controller to the terminal. It can be used in the register mode (REG = 1) or in process data transfer (REG = 0). The gain and offset of the terminal can be adjusted with the control byte (process data transfer). The code word must be entered in R31 to enable adjustment of the terminal. The terminal's gain and offset can then be adjusted.

The parameters are not permanently stored until the code word is reset!

Control byte:

Bit7 = 0

Bit6 = 1 Terminal adjustment function is activated

Bit4 = 1 gain adjustment

Bit2 = 0 slow clock = 1000ms

1 fast clock = 50ms

Bit1 = 1 up

Bit0 = 1 down

Bit3 = 1 offset adjustment

Bit2 = 0 slow clock = 1000ms

1 fast clock = 50ms

Bit1 = 1 up

Bit0 = 1 down

Status byte

in process data transfer

The status byte is transferred from the terminal to the controller. The status byte contains various status bits of the analog input terminal KL3022:

Status byte:

Bit 7 = 0

Bit6= 1: ERROR – General error bit

Bit4 | Bit5

0 | 0 Limit 2 not activated

0 | 1 Process data less than Limit 2

1 | 0 Process data more than Limit 2

1 | 1 Process data equal to Limit 2

Bit2 | Bit3

0 | 0 Limit 1 not activated

0 | 1 Process data less than Limit 1

1 | 0 Process data more than Limit 1

1 | 1 Process data equal to Limit 1

Bit1= 1: Over range

Bit0= 1: Under range

Annex

As already described in the chapter on terminal configuration, each bus terminal is mapped in the bus coupler. In the standard case, this mapping is done with the default setting in the bus coupler / bus terminal. This default setting can be modified with the TRS Configuration software KS2000 or using Master Configuration (eg ComProfibus). The following tables provide information on how the KL3022 maps itself in the bus coupler depending on the set parameters.

Mapping in the bus coupler

The KL3022 is mapped in the bus coupler depending on the set parameters. If the terminal is evaluated completely, the terminal occupies memory space in the process image of the inputs and outputs.

Complete evaluation = 0 MOTOROLA format = 0 Word alignment = X	I/O Offset	High Byte	Low Byte
	3		
	2		
	1	D1 - 1	D0 - 1
	0	D1 - 0	D0 - 0
Complete evaluation = 0 MOTOROLA format = 1 Word alignment = X	I/O Offset	High Byte	Low Byte
	3		
	2		
	1	D0 - 1	D1 - 1
	0	D0 - 0	D1 - 0
Complete evaluation = 1 MOTOROLA format = 0 Word alignment = 0	I/O Offset	High Byte	Low Byte
	4		
	3	D1 - 1	D0 - 1
	2	CT/ST - 1	D1 - 0
	1	D0 - 0	CT/ST - 0
Complete evaluation = 1 MOTOROLA format = 1 Word alignment = 0	I/O Offset	High Byte	Low Byte
	4		
	3	D0 - 1	D1 - 1
	2	CT/ST - 1	D0 - 0
	1	D1 - 0	CT/ST - 0
Complete evaluation = 1 MOTOROLA format = 0 Word alignment = 1	I/O Offset	High Byte	Low Byte
	4	D1 - 1	D0 - 1
	3		CT/ST - 1
	2	D1 - 0	D0 - 0
	1		CT/ST - 0
Complete evaluation = 1 MOTOROLA format = 1 Word alignment = 1	I/O Offset	High Byte	Low Byte
	4	D0 - 1	D1 - 1
	3		CT/ST - 1
	2	D0 - 0	D1 - 0
	1		CT/ST - 0

Legend

Complete evaluation: the terminal is mapped with control / status byte.

Motorola format: The Motorola or Intel format can be set.

Word alignment: The terminal is at a word limit in the bus coupler.

CT: Control Byte (appears in the PI of the outputs).

ST: Status Byte (appears in the PI of the inputs).

D0 - 0 : D0 = Data-Low-Byte, 0 = Channel 0

D1 - 1 : D1 = Data-High-Byte, 1 = Channel 1

Table of the KL3022 register set

Address	Description	Default	R/W	Storage medium
R0	Raw ADC value	variable	R	RAM
R1	not used	0x0000	R	
R2	not used	0x0000	R	
R3	not used	0x0000	R	
R4	not used	0x0000	R	
R5	not used	0x0000	R	
R6	Diagnostic register	variable	R	RAM
R7	Command register - not used	0x0000	R	
R8	Terminal type	3022	R	ROM
R9	Software version number	0x????	R	ROM
R10	Multiplex-shift register	0x0218	R	ROM
R11	Signal channels	0x0218	R	ROM
R12	minimum data length	0x0098	R	ROM
R13	Data structure	0x0000	R	ROM
R14	not used	0x0000	R	
R15	Alignment-register	variable	R/W	RAM
R16	Hardware version number	0x????	R/W	SEEROM
R17	Hardware offset adjustment	specific	R/W	SEEROM
R18	Hardware gain adjustment	specific	R/W	SEEROM
R19	Manufacturer scaling: offset	0x0000	R/W	SEEROM
R20	Manufacturer scaling: gain	0x2002	R/W	SEEROM
R21	Over range limit	0x0FFF	R/W	SEEROM
R22	Under range limit	0x0000	R/W	SEEROM
R23	ADC hardware preset	0x0000	R/W	SEEROM
R24	not used	0x0000	R/W	SEEROM
R25	not used	0x0000	R/W	SEEROM
R26	not used	0x0000	R/W	SEEROM
R27	not used	0x0000	R/W	SEEROM
R28	not used	0x0000	R/W	SEEROM
R29	not used	0x0000	R/W	SEEROM
R30	not used	0x0000	R/W	SEEROM
R31	Code word register	variable	R/W	RAM
R32	Feature register	0x1106	R/W	SEEROM
R33	User offset	0x0000	R/W	SEEROM
R34	User gain	0x0100	R/W	SEEROM
R35	Limit 1	0x0000	R/W	SEEROM
R36	Limit 2	0x0000	R/W	SEEROM
R37	not used	0x0000	R/W	SEEROM
R38	not used	0x0000	R/W	SEEROM
R39	not used	0x0000	R/W	SEEROM
R40	not used	0x0000	R/W	SEEROM
R41	not used	0x0000	R/W	SEEROM
R42	not used	0x0000	R/W	SEEROM
R43	not used	0x0000	R/W	SEEROM
R44	not used	0x0000	R/W	SEEROM
R45	not used	0x0000	R/W	SEEROM
R46	not used	0x0000	R/W	SEEROM
R47	not used	0x0000	R/W	SEEROM