

BK-3XX0

Technical Documentation Profibus coupler

Please keep for further use !

Edition date/Rev. date: 15.05.1998
Document no./Rev. no.: TRS - V - BA - GB - 0063 - 00
Software version: 1.3
File name: TRS-V-BA-GB-0063.DOC
Author: KOH

TRSystemtechnik GmbH
Eglisshalde 6
D-78647 Trossingen
Germany
Tel. +49 - (0) 7425 / 228-0
Fax +49 - (0) 7425 / 228-34

Imprint

TRSystemtechnik GmbH

D-78647 Trossingen
Eglisshalde 6
Tel.: (+49) 07425/228-0
Fax: (+49) 07425/228-34

© Copyright 1998 TRSystemtechnik

Guarantee

In our ongoing efforts to improve our products, TRSystemtechnik reserve the right to alter the information contained in this document without prior notice.

Printing

This manual was edited using text formatting software on a DOS personal computer. The text was printed in *Arial*.

Fonts

Italics and **bold** type are used for the title of a document or to emphasize text passages.

Passages written in *Courier* show text which is visible on the display as well as software menu selections.

"< >" refers to keys on your computer keyboard (e.g. <RETURN>).

Note

Text following the "NOTE" symbol describes important features of the respective product.

Copyright Information ©

MS-DOS is a registered trademark of Microsoft Corporation.

Revision History

i

Note:

The cover of this document shows the current revision status and the corresponding date. Since each individual page has its own revision status and date in the footer, there may be different revision statuses within the document.

Document created:

15.05.1998

Revision	Date

Table of contents

Basic information	5
The TRS bus terminal system	5
The interfaces.....	7
The operating modes of the bus coupler	9
Mechanical construction.....	9
The peripheral data in the process image.....	13
Starting operation and diagnostics	15
PROFIBUS coupler BK3xx0 in the PROFIBUS DP	18
Introducing the system.....	18
PROFIBUS DP	18
The transfer medium: plugs and cables.....	24
Appendix	27
Combined operation with PROFIBUS DP and PROFIBUS FMS	27
PROFIBUS FMS.....	28
Sample arrangement of a process image in the bus coupler.....	30
Representation of analog signals in the process image	32
PROFIBUS DP Setting parameters.....	34
Configuration	35
Diagnostics.....	38
Other DP services.....	41

Basic information

The TRS bus terminal system

Up to 64 bus terminals

*each with 2 I/O channels
for any form of signal*

*Decentralized wiring of the
I/O level*

IPC as control unit

*Bus couplers for all current
bus systems*

Standard C rail assembly

Modularity

Display of channel status

The K bus

The bus terminal system is the universal connecting link between a fieldbus system and the sensor/actor level. A unit consists of a bus coupler, which is the interface to the fieldbus, and up to 64 electronic terminals, of which the last is an end terminal. Terminals, each with two I/O channels, are available for any form of technical signal and can be combined as desired. The various types of terminal are all constructed in the same way, so that the planning costs are kept extremely low. The height and depth of the construction are calculated for compact terminal cabinets.

Fieldbus technology makes it possible to use compact control architectures. The I/O level does not need to be taken right up to the control unit. Sensors and actors can be connected decentrally with minimal lengths of cable. You can position the control unit at any convenient location in the installation. Using an industrial PC as control unit makes it possible to implement the operating and monitoring element as part of the control hardware, so the control unit can be located on an operating desk, control point or similar. The bus terminals constitute the decentralized input/output level of the control unit in the switch cabinet and its subordinate terminal cabinets. As well as the sensor/actor level, the power unit of the equipment is also controlled via the bus system. The bus terminal replaces a conventional terminal as the cabling level in the switch cabinet; the switch cabinet can be made smaller.

The TRS bus terminal system combines the advantages of a bus system with the functionality of compact terminals. Bus terminals can be used on all current bus systems and serve to reduce the diversity of parts in the control unit, while behaving like the conventional standard units for the relevant bus system and supporting the entire range of functionality of the bus system.

The simple and compact assembly on a standard C rail, and the direct cabling of actors and sensors without cross connections between the terminals, serve to standardize the installation, as does the uniformly designed labeling.

The small size and great flexibility of the bus terminal system mean that you can use it anywhere that you could use a terminal and use any type of connection – analog, digital, serial or direct sensors.

The modular construction of the terminal row, using bus terminals with various functions, limits the number of unused channels to at most one per function. Two channels to a terminal is the optimum solution for the number of unused channels and the cost per channel. The possibility of using power input terminals to provide separate power supplies also helps to minimize the number of unused channels.

The integrated light-emitting diodes close to the sensor/actor indicate the status of each channel.

The K bus is the path taken by data within the terminal row. The bus coupler carries the K bus through all the terminals by means of six contacts

End terminal

on the side walls of the terminals, and the end terminal terminates the K bus. The user does not need to know anything about the function of the K bus or the internal operation of terminals and bus couplers. There are numerous software tools available which provide for convenient planning, configuration and operation.

Power input terminals for separately powered groups

Three power contacts pass the operating power to the following terminals. You can use power input terminals to subdivide the terminal row as desired into groups, each with a separate power supply. These power input terminals are not taken into account for addressing the terminals, you can insert them at any position along the terminal row. You can install up to 64 terminals on a terminal row, including power input terminals and the end terminal.

The principle of the bus terminal

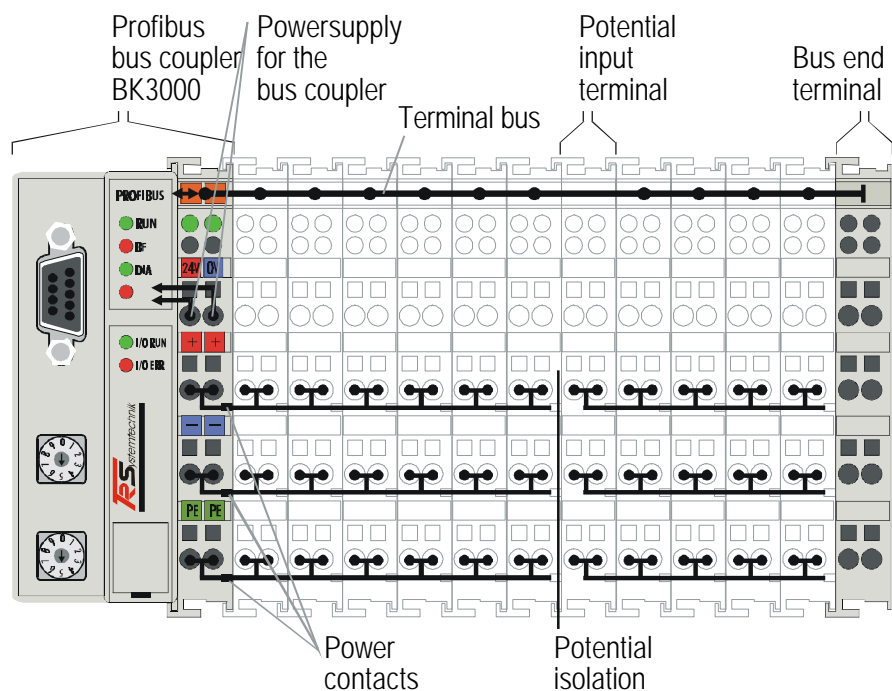

Bus couplers for various fieldbus systems

You can use a variety of bus couplers to attach the electronic terminal row quickly and easily to the various fieldbus systems, and you can also subsequently convert to a different fieldbus system. The bus coupler deals with all the necessary monitoring and control tasks for operating the attached bus terminals, indeed all the operation and configuration of the bus terminals is carried out via the bus coupler. The fieldbus, K bus and I/O level are electrically isolated. If the exchange of data across the fieldbus is temporarily interrupted, logic states are preserved, digital outputs are cleared and analog outputs revert to a reset value which can be individually configured for each output when the equipment is set up.

The interfaces

There are six ways of making a connection to a bus coupler. These interfaces are designed as plug connections and spring terminals.

The Profibus coupler BK3000

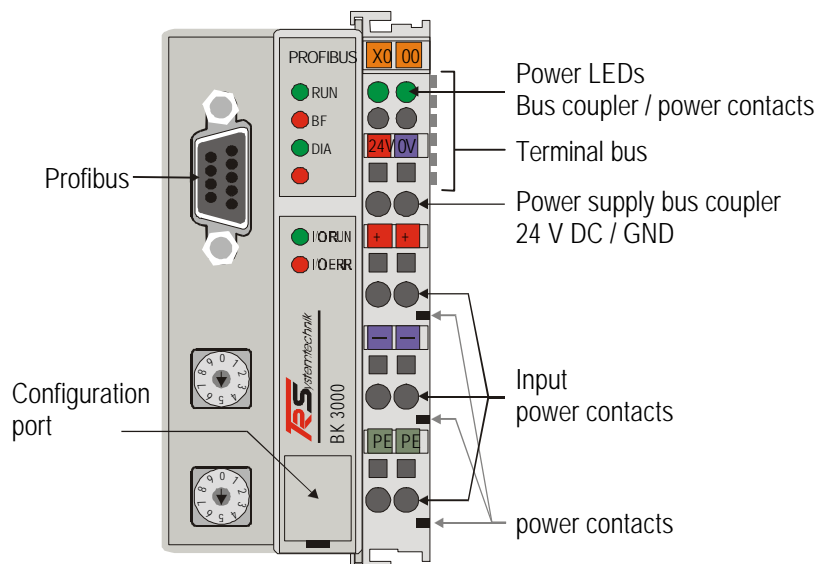

Power supply

24 V DC on the topmost terminals "24 V" and "0 V"

The bus couplers need an operating power of 24 V DC which is connected via the topmost spring terminals, labeled "24 V" and "0 V". This power supply serves not only the electronic components of the bus coupler but (via the K bus) also the bus terminals. The power supply of the bus coupler circuitry and that of the K bus are electrically isolated from the voltage of the field level.

Power supply to the power contacts

Lower 3 terminal pairs for power input

maximum 24 V

maximum 10 A

The six lower connections with spring terminals can be used to supply power to the peripherals. The spring terminals are connected in pairs to the power contacts. The power supply to the power contacts has no connection to the power supply of the bus couplers. The power input is designed to permit voltages up to 24 V. The pair-wise arrangement and the electrical connection between the feed terminal contacts makes it possible to loop through the wires connecting to different terminal points. The load on the power contact may not continuously exceed 10 A. The current capacity between two spring terminals is the same as the capacity of the connecting wires.

Power contacts

Spring contacts at the side

On the right-hand side face of the bus coupler are three spring contacts which are the power connections. The spring contacts are recessed in slots to prevent them from being touched. When a bus terminal is connected, the blade contacts on the left-hand side of the bus terminal are connected to the spring contacts. The slot and key guides at the top and bottom of the bus couplers and bus terminals ensure reliable location of the power contacts.

9-pin Sub-D female connector

Fieldbus connection

On the left-hand side there is a flat recessed area where you can plug in the typical Profibus male connectors. You will find a detailed description of the fieldbus interfaces in another part of this manual (In the chapter "The transfer medium: plugs and cables").

Serial interface under the front flap

Configuration interface

On the lower part of the front face you will find the standbus couplers which are fitted with an RS232 interface. The miniature plug can be attached to a PC by means of a connection cable and the configuration software BS2000. This interface enables you to configure the analog channels. You can also access the functionality of the configuration interface via the fieldbus by means of the ADS communications.

6 contacts at the side

K bus contacts

The connections between the bus coupler and the bus terminals are effected by gold contacts at the right-hand side of the bus coupler. When the bus terminals are plugged together, these gold contacts automatically complete the connection to the bus terminals. The K bus is responsible for the power supply to the electronic components of the K bus in the bus terminals, and for the exchange of data between the bus coupler and the bus terminals. Part of the data exchange takes place via a ring structure within the K bus. Disengaging the K bus, for example by pulling on one the bus terminals, will break this circuit so that data can no longer be exchanged. However, there are mechanisms in place which enable the bus coupler to locate the interruption and report it.

*3 supply groups:
fieldbus
K bus
peripheral level*

Supply isolation

The bus couplers operate with three independent supplies. The input power supplies the electrically isolated K bus circuitry in the bus coupler and the K bus itself. The power supply is also used to generate the operating power for the fieldbus.

Note: All the bus terminals are electrically isolated from the K bus, so that the K bus is completely electrically isolated.

Setting up the power levels in the bus terminal system

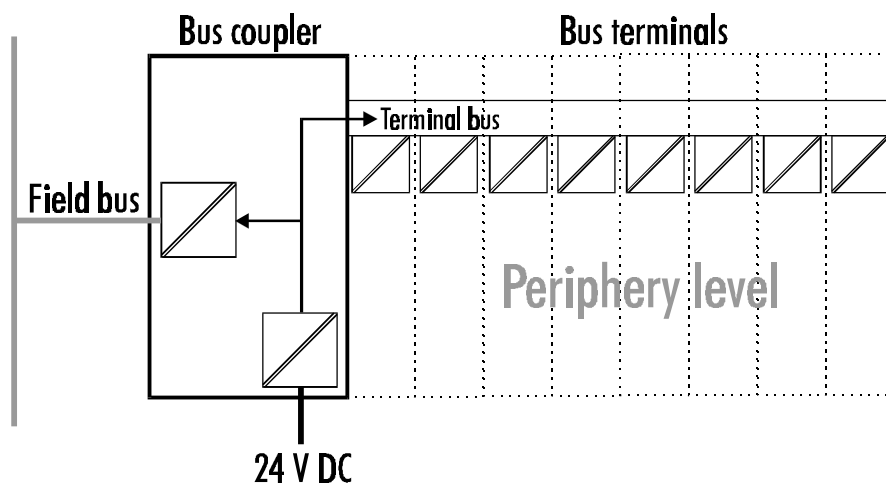

The operating modes of the bus coupler

When it is first switched on the bus coupler carries out a self-test to check the functions of its components and the communications of the K bus, and while this is going on the red I/O LED will flash. When the self-test has been completed successfully, the bus coupler will begin to test the attached bus terminals (the "bus terminal test") and read in the configuration from which it constructs an internal structure list, which is not accessible from outside. If an error occurs the bus coupler will enter the operating mode "STOP". If the start-up sequence is completed without errors the bus coupler will enter the mode "fieldbus start".

Start-up behavior of the bus coupler

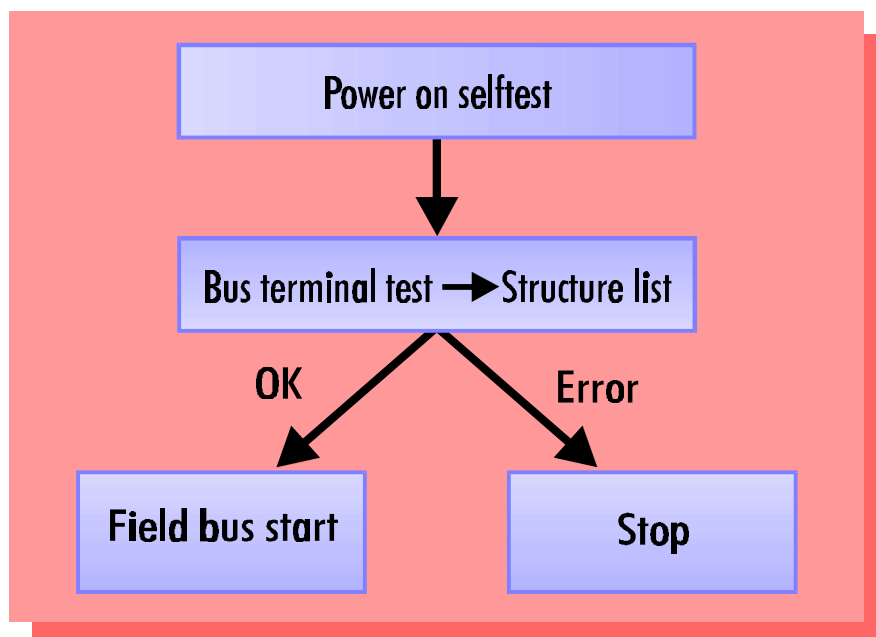

The bus coupler reports the error to the master by means of the Profibus diagnostics. Clearing the error returns the bus coupler to its normal operating mode.

Mechanical construction

The TRS bus terminal system is remarkable for its compact construction and high degree of modularity. When you design the installation you will need to plan for one bus coupler and some number of bus terminals. The dimensions of the bus couplers do not depend on the fieldbus system. If you use large plugs, for example like some of the bus plugs used for the Profibus, they may protrude above the overall height of the cabinet.

Dimensions of a bus coupler

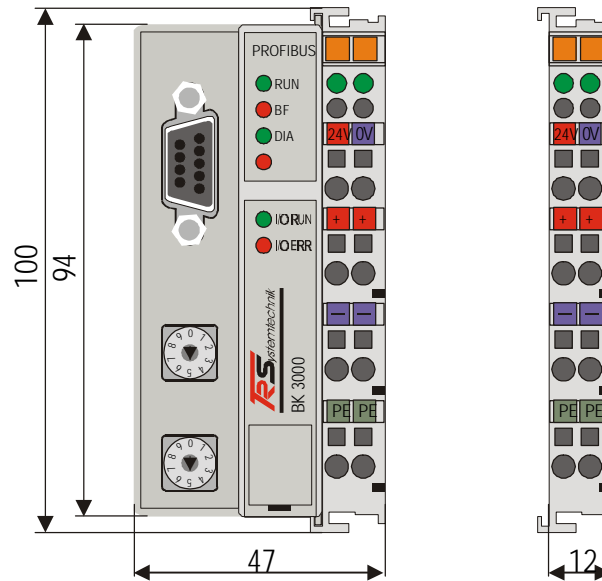

The overall width of the construction is the width of the bus coupler, including the bus end terminal, plus the width of the installed bus terminals. The bus terminals are 12 mm or 24 mm wide, depending on their function. Depending on the gauge of cables used the overall height of 68mm may be overstepped by about 5 mm to 10 mm by the cables at the front.

Assembly and connections

It takes only a slight pressure to latch the bus coupler and the various bus terminals onto a supporting 35mm C rail and a locking mechanism then prevents the individual housings from being removed. You can remove them without effort if you first release the latching mechanism by pulling the orange tab. You should carry out work on the bus terminals and the bus coupler only while they are switched off: if you plug or unplug components while the power is on you may briefly provoke some undefined state (and, for instance, reset the bus coupler).

You can attach up to 64 bus terminals in series on the right-hand side of the bus coupler. When you assemble the components, make sure that you mount the housings so that each slot comes together with the corresponding key. You cannot make any functional connections merely by pushing the housings together along the supporting track. When they are correctly mounted there should be no appreciable gap between the adjacent housings.

The right-hand side of a bus coupler is mechanically similar to a bus terminal. There are eight connections on the top which can be used to connect to thick-wire or thin-wire lines. The connection terminals are spring loaded. You open a spring terminal by applying a slight pressure with a screwdriver or other pointed tool in the opening above the terminal and you can then insert the wire into the terminal without any obstruction. When you release the pressure the terminal will automatically close and hold the wire securely and permanently.

The connection between bus couplers and bus terminals is automatically effected by latching the components together. The K bus is responsible for passing data and power to the electronic components of the bus terminals. In the case of digital bus terminals, the field logic receives power via the power contacts. Latching the components together has the effect that the series of power contacts constitutes a continuous power track. Please refer to the circuit diagrams of the bus terminals: some bus terminals do not loop these power contacts through, or not completely (e.g. analog bus terminals or 4-channel digital bus terminals). Each power input terminal interrupts the series of power contacts and constitutes the beginning of a new track. The bus coupler can also be used to supply power to the power contacts.

Insulation test

The power contact labeled "PE" can be used as protective earth or ground. This contact stands proud for safety reasons and can carry short-circuit currents of up to 125A. Note that in the interests of electromagnetic compatibility the PE contacts are capacitively connected to the supporting track. This may lead to spurious results and even damage to the terminal when you test the insulation (e.g. insulation test for breakdown using a 230V mains supply to the PE line). You should therefore disconnect the PE line on the bus coupler while you carry out insulation tests. You can disconnect other power supply points for the duration of the test by drawing the power supply terminals out from the remaining row of terminals by at least 10mm. If you do this, there will be no need to disconnect the PE connections.

PE power contacts

The protective earth power contact ("PE") may not be used for any other connections.

Electrical data

Profibus couplers may have different configuration levels. The electrical data specific to the fieldbus is listed in the appropriate chapter. The following data distinguishes between the standard version and the economy version (BK3000 and BK3010). Either version is fully compatible to the Profibus, but the economy version has no configuration interface and has only a limited number of I/O points, which is why it permits you to attach only digital inputs and outputs.

Technical data	Profibus coupler BK3000	Economy coupler BK3010
Voltage supply	24 V, + / - 10%	
Input current	105 mA typical 900 mA max.	85 mA typical 500 mA max.
Output current K bus	2A max.	1A max.
Supply isolation	3500 Veff (K bus / supply voltage)	
Number of bus terminals	64	
Digital peripheral signals	256 inputs and outputs	32 inputs and 32 outputs
Analog peripheral signals	122 inputs and outputs #1	--
Peripheral bytes	244 input #1 and 244 output bytes	4 input and 4 output bytes
Configuration interface	Available for BS2000	--
Baud rates	Standards-conform, automatic recognition up to 1.5 MBaud (12 Mbaud)	
Voltage power contact	24V DC / AC	
Current load power con.	10 A	
Max. short circuit current	125 A	
Max. voltage capacity	4000 Veff (power contact / supply voltage)	
Housing	BKG 1334 b	
Weight approx.	170g	
Operating temperature	0°C ... +55°C	
Storage temperature	-20°C ... +85°C	
Relative humidity	95% non-condensing	
Vibration /shock resistance	according to IEC 68-2-6 / IEC 68-2-27	
Interference resistance. Burst / ESD	according to IEC 801-4 / IEC 801-2, stringency 3	
Orientation for mounting	Any	
Type of fuse	IP20	

#1 The master interface IM308-B supports 58 consistent input bytes maximum. The master interface IM308-C supports 122 consistent input bytes maximum. Other master interfaces have other comparable restrictions.

Technical data	Bus coupler
Voltage supply	30 V
Input current	900 mA max.
Output current K bus	2A max.
Peak voltage	5000 V (K bus / supply voltage)
Voltage power contact	60V AC/DC
Current capacity power con.	10 A, permanent load
Current capacity power con.	12 A, < 2min
Current capacity power con.	125 A peak load, short circuit
Voltage capacity	4000 Veff (power contact / fieldbus signal voltage)
Housing	BKG 1334 b
Weight	190g
Operating temperature	0°C ... +55°C
Storage temperature	-20°C ... +85°C
Relative humidity	95% non-condensing

The peripheral data in the process image

When the bus coupler is first switched on it determines the configuration of the attached input/output terminals and automatically assigns the physical slots of the input/output channels to the addresses in the process image.

The bus coupler sets up an internal list of assignments in which each of the input and output channels has a specific position in the process image. A distinction is made here between input and output and between bit-oriented (digital) and byte-oriented (analog, or complex) signal processing.

It also forms two groups, whereby one contains only inputs and the other only outputs. In each group, the byte-oriented channels take the lowest addresses, in ascending order, and these are then followed by the bit-oriented channels.

Digital signals (bit-oriented)

Digital signals are bit-oriented. This means that one bit of the process image is assigned to each digital channel. The bus coupler sets up a block of memory containing the current input bits and arranges to immediately write out the bits from a second block of memory which belongs to the output channels.

The precise assignment of the input and output channels to the process image of the control unit is explained in detail in the Appendix by means of an example.

Analog signals (byte-oriented)

The processing of analog signals is always byte-oriented and analog input and output values are stored in memory in a two-byte representation. The values are held as "SIGNED INTEGER" or "twos-complement". The digit "0" represents the input/output value "0V", "0mA" or "4mA". When you use the default settings, the maximum value of the input/output value is given by "7FFF" hex. Negative input/output values, such as -10V, are represented as "1000" hex and intermediate values are correspondingly proportional to one another. The full range of 15-bit resolution is not realized at every input/output level. If you have an actual resolution of 12 bits, the remaining three bits have no effect on output and are read as "0" on input. Each channel also possesses a control and status byte in the highest value byte, although version 2.0 of the Profibus coupler does not permit the control and status byte to be read. An analog channel is represented by 2 bytes in the process image.

Special signals and interface

A bus coupler supports bus terminals with additional interfaces, such as RS232, RS485, incremental encoder, etc.. These signals can be regarded in the same way as the analog signals described above. A 16-bit data width may not be sufficient for all such special signals; the bus coupler can support any data width.

Default assignment of inputs and outputs to the process image

When the bus coupler is first switched on it determines the number of attached bus terminals and sets up a list of assignments. This list distinguishes between analog channels and digital channels and between input and output; which are grouped separately. The assignments begin immediately to the left of the bus coupler. The software in the bus coupler creates the assignment list by collecting the entries for the individual channels one at a time, counting from left to right. These assignments distinguish four groups:

	Function type of the channel	Assignment level
1.	Analog outputs	byte-wise assignment
2.	Digital outputs	bit-wise assignment
3.	Analog inputs	byte-wise assignment
4.	Digital inputs	bit-wise assignment

Complex multi-byte signal bus terminals are represented as analog inputs or outputs

Overview of the subdivision of the process image in the bus coupler:

Output data in the bus coupler

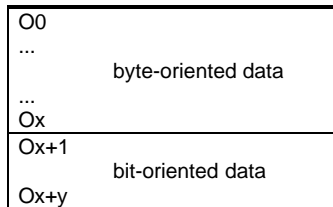

Input data in the bus coupler

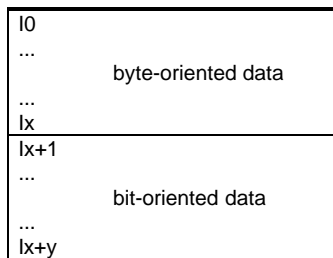

The path from the I/Os to the PROFIBUS process image

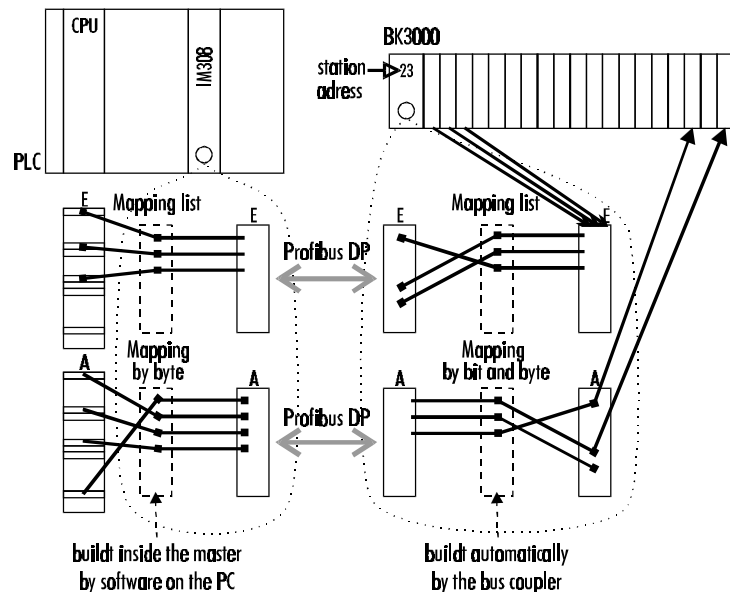

Data consistency

Data which contains no contradictions is said to be consistent. The following consistency is required here: 1. The high byte and low byte of an analog value (word consistency), 2. The control/status byte and the corresponding parameter word for accessing the register. The interaction of the peripherals with the control unit means that data can initially be guaranteed consistent only within an individual byte: the bits which make up a byte are read in together, or written out together. Byte-wise consistency is quite adequate for processing digital signals but is not sufficient for transferring values longer than eight bits, such as analog values. The various bus systems guarantee consistency to the required length. It is important to use the appropriate procedure for importing this consistent data from the master bus system to the control unit. You will find a detailed description of the correct procedure in the User Guide of the appropriate bus system, in particular in the description of the standard master units that are installed. The chapters of this manual which deal with the fieldbus refer to the most common of these standard units.

Processing complex signals

All byte-oriented signal channels such as RS232, RS485 and incremental encoder, can use byte lengths greater than two. Apart from the actual difference in length, the procedure is always comparable with that for analog signals.

Starting operation and diagnostics

When the bus coupler is first switched on it at once checks the attached configuration. A correct start-up procedure is indicated by the red LED "I/O ERR" going out. If this LED flashes, this indicates a fault somewhere in the terminals. You can determine the actual error code by observing the speed of flashing and number of flashes. This will enable you to clear the fault quickly. You will find a detailed description in the chapter "The diagnostic LEDs".

The diagnostic LEDs

The bus coupler has a status display consisting of two groups of LEDs. The upper group has four LEDs which indicate the mode of the installed fieldbus. The significance of these "fieldbus status LEDs" is explained in the appropriate chapters of this manual; they correspond to the usual displays for fieldbuses.

There are two more green LEDs at the top right-hand side of the bus coupler to indicate the supply voltage. The left-hand LED shows the 24V supply of the bus coupler. The right-hand LED shows the supply to the power contacts.

Local errors

Two LEDs, the “I/O LEDs”, which are situated below the fieldbus status LEDs described above, are used to display the operating mode of the bus terminals and the connection to these bus terminals. The green LED lights up to indicate error-free operation, where “error-free” implies that communication with the fieldbus system is also operating correctly. The red LED flashes at two different rates to indicate a fault, whereby the specific error is encoded in the pattern of flashes, as follows.

Code of flashes

Rapid flashing	Start of the error code
First slow sequence	Type of error
Second slow sequence	Location of error

Type of error

1 flash	
2 flashes	
3 flashes	Connection to the bus terminals cannot be set up correctly
4 flashes	Break in the K bus

Location of error

The number of flashes corresponds to the position of the last bus terminal before the error, not counting passive bus terminals such as power input terminals.

The bus coupler will carry on flashing the error code even when you have cleared the fault and its operating mode will remain at “Stop”. The only way to restart the bus coupler is by switching the power supply off and on again.

You should not plug or unplug bus terminals from the series without first turning off the power. The circuitry of the bus terminals and the bus coupler is largely protected against damage, but if you modify the assembly while it is under power, malfunctions and damage cannot be ruled out.

If a fault occurs during normal operation, the error code will not be output on the LEDs until the bus coupler has been requested to diagnose the bus terminals. This diagnostic request is generated after the equipment is switched on.

Fieldbus errors

The fieldbus status LEDs indicate the current operating mode of the fieldbus. The functions of the Profibus are shown by the LEDs "RUN", "BF" and "DIA"; the fourth LED has no significance.

RUN LED	BF	DIA	Significance	Remedy
lit	off	off	Operating mode: RUN Inputs are read and outputs are set.	
off	flashing	off	Operating mode: CLEAR (green I/O LED is lit) Inputs are read; outputs are not set; Operating mode: STOP (green I/O LED is off) No data is exchanged over the Profibus	- Start the master afresh (configuration error?) - Start the master
off	lit	off	Bus errors (physical) e.g. short-circuit, open circuit	Check: # that the bus cable is plugged into the master # that the bus cable is intact
off	off	off	No function: if the power LED on the right is lit, there is a serious error; if the power LED is not lit, the power supply has failed	# Replace the bus coupler # Check the power supply
flashing	off	off		
off	off	flashing		

Please note that there is an association between the green I/O LED and the fieldbus. The I/O LED lights up when access is made to the internal K bus. The green I/O LED is not lit until data begins to be exchanged via the fieldbus, because the Profibus initiates a new data exchange on the K bus each time it accesses the bus coupler, which means that the fieldbus has to access the bus coupler.

The green I/O LED lights up when access is made to the internal K bus. However, when it is first switched on, the bus coupler interrogates the configuration of the bus terminals and does not exchange any data with the terminals at this point. This means that the red I/O LED will go out after an error-free start-up, although the green I/O LED will not necessarily be lit, and in this case it will not light up until data begins to be exchanged over the fieldbus.

PROFIBUS coupler BK3xx0 in the PROFIBUS DP

Introducing the system

The PROFIBUS enjoys a very wide acceptance in automation technology due to its openness and its wide manufacturer-independent distribution. The PROFIBUS was developed in the course of a group project on the fieldbus concept which aimed at agreeing on a standard. Numerous different products are now available from independent manufacturers which all conform to the standard DIN 19245 parts 1 and 2. Standards-conform PROFIBUS devices can be operated on any bus system.

PROFIBUS specifies the technical and functional characteristics of a serial fieldbus system which can be used to network distributed digital and analog field automation devices with low range (sensor/actuator level) to midrange performance (cell level). PROFIBUS makes a distinction between master and slave devices; master devices are those which govern the data traffic on the bus.

A master may send messages without an external request, provided it has the authority to access the bus. The PROFIBUS protocol also describes masters as “active subscribers”.

Slave devices are peripheral devices. Typical slave devices are sensors, actors, signal transformers and the TRS bus couplers BK3000, BK3100, BK3110 and BK3010. They are not given authority to access the bus, so they may only acknowledge the messages they receive, or pass messages to a master when requested to do so. Slaves are also described as “passive subscribers”. TRS bus couplers are passive subscribers which support PROFIBUS DP and PROFIBUS FMS. They are also described as “FMS/DP combislaves”.

PROFIBUS DP

PROFIBUS DP is designed for rapid data exchange at sensor/actor level, where centralized control devices (such as stored program control units) communicate with decentralized input and output devices by means of a fast serial connection. The exchange of data with these decentralized devices is carried out predominantly cyclically. The centralized control unit (master) reads the input data from the slaves and writes the output data to the slaves, whereby the cycle time of the bus needs to be shorter than the program cycle time of the central control unit, which will be under 10 ms in many applications.

Rapid data throughput alone is not sufficient for the successful implementation of bus system. Ease of handling, good diagnostic facilities and fault-proof data transfer technology must all be provided in order to fulfill the users' requirements. The characteristics have been optimally combined in PROFIBUS DP.

At a transfer rate of 1.5 Mbit/s (BK3000 and BK3010) PROFIBUS DP will take 6 ms to transfer 512 bits of input data and 512 bits of output data distributed to 32 subscribers, and at 12 Mbit/s (BK3100 and BK3110) less than 2 ms. This fulfills the requirement for a fast system response time.

System configurations and device types

You can use PROFIBUS DP to implement mono-master or multi-master systems, which gives you a high degree of flexibility as regards the system configuration. Up to 126 miscellaneous devices (master or slaves) can be attached to one bus. The bus couplers BK3xx0 permit you to select a station address between 0 and 99. The quantities specified in the system configuration include the number of stations, the assignments of station addresses to I/O addresses, the consistency of the I/O data, the format to be used for diagnostic messages and bus parameters that are to be used. Each PROFIBUS DP system is made up of a number of different types of device. We distinguish three types, depending on the tasks involved:

DP master class 1 (DPM1), such as an IM308-B or IM308-C

This is a central control unit which exchanges information with the decentralized stations (DP slaves) in a fixed message cycle. Typical devices include stored program control units (SPS), numeric control units (CNC) or robot control units (RC).

DP master class 2 (DPM2), such as a CP5431 communications board

Devices of this type are programming, planning or diagnostic devices. They are used to configure the DP system when the equipment is set up and taken into service.

DP slave, such as the Profibus coupler BK3000

A DP slave is a peripheral device (sensor/actor), which reads in input information and passes output information to the peripherals. Devices which only input information, or only output information, are also possible. Typical DP slaves are devices with binary I/O ports for 24V or 230V, analog inputs, analog outputs, counters etc.. The volume of input and output information depends on the individual device, up to a maximum of 246 bytes for input data and 246 bytes for output data. Due to cost factors, and for technical and implementational reasons, many of the currently available devices operate with a maximum data length of 32 bytes. The Profibus coupler BK3000 can use the full length of 244 bytes, although the master unit IM308-C restricts this to 52 bytes for input data. The IM308-B enables you to use up to 122 bytes of input data.

In a mono-master system, only one master is active on the bus during the operating phase of the bus system. The SPS control unit is the central control element. The DP slaves are coupled to the SPS control unit decentrally by means of the transfer medium. This system configuration achieves the shortest bus cycle time.

In multi-master operation there are a number of masters on a single bus. These either constitute independent subsystems, each consisting of one DPM1 and the corresponding DP slaves or additional planning and diagnostic devices. All the DP masters can read the input and output mappings of the DP slaves. Although the output can be written by only one DP master (namely the DPM1 which was appointed when the system was specified). Multi-master systems achieve an average bus cycle time. If timing is critical to your application you should connect up a diagnostic tool to monitor increases in the bus cycle time.

Device master file (DMF)

The manufacturers of PROFIBUS DP provide users with documentation covering the performance characteristics of the devices, in the form of a device data sheet and a device master data file. The layout, content and coding of this device master data (the DMF) are standardized. It facilitates convenient project planning with any desired DP slaves using planning devices from a variety of manufacturers. The PNO archives this information for all manufacturers and will supply information on request about manufacturers' device master files.

A PROFIBUS master configuration program reads the DMF data and transfers the appropriate settings to the master. You will find a description of this in the relevant software manual supplied by the manufacturer of your master.

Type file (200)

One of the most common and most user-friendly master units for an SPS is Siemens' IM308-C. The Windows software COMWIN is available for configuring the master. The task of configuring this master unit for the PROFIBUS is supported by the manufacturers' documentation which describes the performance characteristics of the slave devices. This is supplied to users in the form of a type file. The same applies to the IM308-B, although the software COMET200.COM provides a more modest operating environment. The layout, content and coding of the type file are Siemens-specific and are supported by TRS, as by other manufacturers. This file facilitates convenient project planning for any desired DP slaves on a PC under the graphical user interface Windows 3.1. The PNO does not yet support all of this information, but will supply information on request about manufacturers' type files. Type files and bitmaps are available for TRS Profibus couplers.

Contact the mailbox 0 52 46 / 96 3 - 45 5, AREA 15,

to download the type file or to order it on a diskette. The name of the file for the IM308-B is "BK3x00TE.200", and the file for the IM308-C is called "BK3x00AE.200". If you use German versions of COMET200.COM and WINCOM.COM you should download the files "BK3000TD.200" and "BK3000AD.200" respectively.

Diagnostic functions

The extensive diagnostic functions of PROFIBUS DP make it possible to localize errors rapidly. The diagnostic messages are transferred via the bus and collated by the master. They are subdivided into three levels:

Diagnostic type	
Station-related	Messages dealing with the general operating condition of a subscriber, such as overheating or low voltage
Module-related	These messages indicate a diagnostic message is pending for a subscriber within a particular I/O sub-area (e.g. 8-bit output module)
Channel-related	This locates the cause of the error in an individual input/ output bit (channel), such as: short circuit on output 2

The bus couplers BK3xx0 support the diagnostic functions of the PROFIBUS DP. The manner in which the control unit evaluates the diagnostic data depends on what support is given by the master. Please refer to the device manual of your master units to see how to handle the diagnostics. (Note for ET200U experts: the diagnostics is device-specific, as for the ET200U; a module in the bus terminal enables you to evaluate the diagnostics for a specific station and track it right down to an individual channel in the bus terminal.)

Sync and Freeze Mode

In addition to the subscriber-related user data traffic, which DPM1 deals with automatically, the DP master can also send control commands to an individual DP slave, to a group, or to all of the slaves simultaneously; these control commands are transferred as multicast functions. You can use such control commands to impose the operating modes Sync and Freeze to synchronize the DP slaves. This facility provides for an event-driven synchronization of the slaves. They enter Sync mode when they receive a Sync control command from their appointed DP master. In this operating mode, the outputs from all the DP slaves are frozen in their current state. If user data is subsequently transferred, the output data is stored at the DP slaves, although the output status values remain unchanged. When the next Sync control command is received from the master, the stored output data is switched through to the outputs. The user can terminate Sync operation by issuing an Unsync control command.

Similarly, a Freeze control command sends the addressed DP slaves into Freeze mode. In this operating mode, the inputs of all the DP slaves are frozen in their current state. The input data is not updated again until the DP master sends the next Freeze control command to the relevant devices. You terminate Freeze operation by issuing an Unfreeze control command.

System behavior

To ensure that the devices are largely exchangeable, the system behavior for the PROFIBUS DP has also been standardized. It depends principally on the operating mode of the DPM1, which can be governed either locally or from the planning device via the bus. The following principal modes are distinguished:

Operating modes	
Stop	No data is transferred between the DPM1 and the DP slaves. The bus coupler addresses the bus terminals only once after the power supply has been turned on and then no more (none of the I/O LEDs is lit)
Clear	The DPM1 reads input information from the DP slaves and maintains the outputs to the DP slaves in a secure state (the outputs are set to logical zero, none of the I/O LEDs is lit)
Operate	The DPM1 is in the data transfer phase. Data is transferred cyclically: inputs are read from the DP slaves and output information is sent to them (the green I/O LED is lit).

The DPM1 uses a multicast command to broadcast its local status cyclically at regular intervals to all its subordinate DP slaves (the interval can be configured). The system's response to an error (such as the failure of a DP slave) which occurs during the data transfer phase of the DPM1 is determined by the operating parameter "Auto Clear". If this parameter has been set to "True", then, as soon as any one DP slave ceases to be ready to transfer user data, the DPM1 will switch the outputs of all its subordinate DP slaves to a stable state and then enter Clear mode. If the parameter is set to "False", then the DPM1 will remain in Operate mode even in an error situation and the user can govern the system response himself.

Data traffic between DPM1 and the DP slaves

The DPM1 automatically deals with data traffic between itself and its subordinate DP slaves in a fixed and continually repeating order. During the planning phase of the bus system, the user specifies which DP slaves belong to which DPM1, which DP slaves should be included in the cyclic transfer of user data, and which should be excluded from it.

The data traffic between the DPM1 and the DP slaves can be subdivided into three phases: parametrization, configuration and data transfer. Before it admits a DP slave to the data transfer phase, the DPM1 checks – in the phases parametrization and configuration – whether the intended configuration from the original plan agrees with the actual device configuration. This check covers the device type, the format and length information and the number of inputs and outputs, all of which must agree. This gives the user reliable protection against parameter errors. In addition to transferring user data, which the DPM1 carries out automatically, it is also possible, at the user's request, to transmit new parameters to the DP slaves.

Protective mechanisms

In the field of decentralized peripherals, security considerations make it imperative that systems should be equipped with highly effective protective functions to prevent incorrect parametrization or a failure of the communications equipment. On both the DP master and the DP slaves, PROFIBUS DP uses monitoring mechanisms which are implemented as timeout monitors. The monitoring interval is specified when the DP system is planned.

On the DP master

The DPM1 uses the Data_Control_Timer to monitor the transfer of user data to and from the DP slaves. A separate monitoring timer is used for each of the subordinate DP slaves. If a monitoring interval elapses without any data being transferred, the monitor will report a timeout. The user will be informed if this occurs. If automatic error response has been specified (Auto_Clear = True), the DPM1 will leave Operate mode, switch the outputs of its DP slaves to a secure state and go into Clear mode.

On the DP slave

Each DP slave maintains a response monitor to enable it to recognize errors in the DP master or the transfer route. If a response monitoring interval elapses without any data being exchanged with the superordinate DP master, the DP slave will independently switch its outputs to the secure state. In the case of a multi-master system additional security is necessary to restrict access to the inputs and outputs of the DP slaves and to ensure that direct accesses are made only by the authorized master. The DP slaves therefore provide the other DP masters with a mapping of their inputs and outputs which can be read by any DP master, even without authority.

Identity number

Each DP slave and each DPM1 must have an individual identity number so that a DP master can recognize the types of the attached devices without entailing a significant protocol overhead. The master compares the identity numbers of the attached DP devices with the identity numbers in the planning data specified by the DPM2. No user data will be transferred unless the correct device types have been attached to the bus with the correct station addresses. This ensures that the system is protected from planning errors.

TRS PROFIBUS couplers, like all DP slaves and DPM1s, possess an identity number allocated by the PNO. The PNO administers these identity numbers together with the device master data and identity numbers are also given in the type files. (The identity number of the bus couplers is HEX AFFE. This is PROVISIONAL until the end of August 1996!!! After this date, please use new type files and DMF files.)

The transfer medium: plugs and cables

The physical data transfer is defined in the PROFIBUS standard. See PROFIBUS layer 1 (physical layer).

The sphere of operation of a fieldbus system is substantially determined by the selected transfer medium and the physical bus interface. Besides the requirements of data transfer security, the necessary expenditure for procuring and installing the bus cable is of crucial significance. The PROFIBUS standard therefore provides for various forms of communications technology while maintaining its standard bus protocol. Cable transfer: this version, which conforms to the US standard EIA RS-485, has been specified as the basic version for applications in the field of production technology, building management technology and drive technology. It uses a single twisted-pair copper cable. Shielding may be unnecessary, depending on the planned application (take electromagnetic compatibility aspects into consideration).

Two types of line are available, with different maximum output lengths, see Table 1. The cabling and the pin-out of the plug connection are shown in the illustration.

Optical cables: the PNO has developed a specification for data transfer technology based on optical cables. This is intended for applications in environments with a high level of electromagnetic interference, and also increases the range for high-speed transmissions. This specification is currently available in the form of a draft PNO guideline. The PROFIBUS COUPLER requires an external module to convert from RS485 to optical cables.

*RS485
Fundamental
characteristics*

RS-485 Data transfer technology to the Profibus standard	
Network topology	Linear bus, active bus terminator at both ends, branch lines are possible
Medium	Shielded twisted cable, shielding may be dispensed with in suitable environments (electromagnetic compatibility)
Number of stations	32 stations in each segment without repeaters, extendible to 127 with repeaters
Max. bus length	
without repeaters	100 m at 12 Mbit/s Cable A: 200 m at 1500 Kbit/s, up to 1.2 km at 93.75 Kbit/s Cable B: 200 m at 500 Kbit/s, up to 1.2 km at 93.75 Kbit/s
with repeaters	Using repeaters (line amplifiers) increases the max. bus length to the order of 10 km. The number of possible repeaters is at least 3 and may be up to 10, depending on the manufacturer
Transfer rates	9.6, 19.2, 93.75, 187.5, 500, 1500 Kbit/s, up to 12 Mbit/s in discrete steps
Plug	9-Pin D-Sub plug

Cables for
PROFIBUS DP and
PROFIBUS FMS

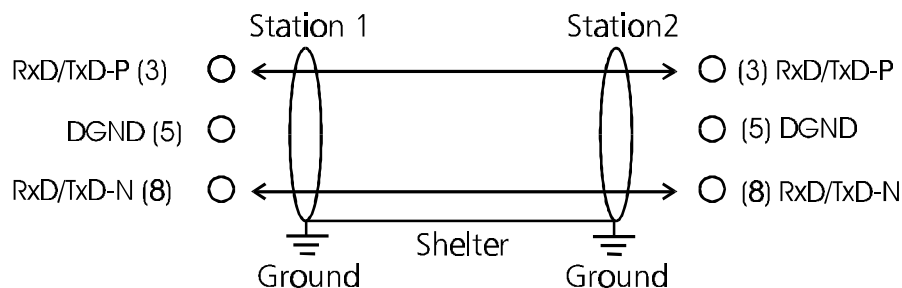

In systems which contain more than two stations, all the subscribers are connected in parallel. The bus cable must always be terminated at the ends of the lines, to prevent reflections and the transmission problems they cause.

In order to loop the cable through without any gaps it is necessary to affix two cables within one plug. Siemens' SINEC L2 bus connections are very suitable for this. These SINEC plugs are constructed to accommodate two bus cables with the corresponding wire terminals and shielding. At the end of the line you can use a small switch in the plug to activate the terminating resistor. Please observe the manufacturer's assembly instructions.

You should also note that the terminating resistor requires a 5 V power supply for optimal operation. This means that if the plug is removed from the bus coupler, or the power supply of the bus coupler fails, the level at the terminating resistor will vary, which may affect the data transfer.

Configuring the master

As explained above, the Profibus coupler sets up a data area containing the input and output bytes. The assignments between the channels of the bus terminals and the bits and bytes of the process image are carried out by the bus coupler.

The Profibus master exchanges a coherent input and output data block with each Profibus coupler. The correlation between the bytes in this data block and the addresses of the process image is carried out by the master. In the case of the IM308-C SPS master, this parametrization is supported by the software COMWIN, and for the IM308-B by the software COMET200. For other masters you should use the corresponding tools provided by the manufacturer (see also the chapters Device master file and Type file).

Support files for configuring the master

Master / Software	Directory	File
IM308-B COMET200	COMET200	BK3000TD.200
IM308-C COMWIN	COMWIN10 / BITMAPS	BUSKLEMN.BMP BUSKLEMS.BMP
	COMWIN10 / TYPDAT5X	BK3000AD.200
General		BK3_BECE.F.DMF

Konfigurieren: BUSKLEMMEN #4 <>				
	Kennung	Kommentar	E-Adr.	A-Adr.
0	177	analoge Ausgabe K.1		P080
1	177	analoge Ausgabe K.2		P082
2	177	analoge Eingabe K.1	P090	
3	177	analoge Eingabe K.2	P092	
4	8DE	dig. Ein Klemme 1..4	P010	
5	8DE	dig. Ein Klemme 5..8	P011	
6	8DA	dig. Aus Klemme 1..4		P012
7				
8				
9				
10				
11				

Example for the master IM308, standard unit for SPS Simatik S5

This window shows the process of configuring an IM308-C with one slave BK3000 and station number 4. The bus coupler BK3000 has the following bus terminals attached:

- 8 x KL1002,
- 4 x KL2012,
- 1 x KL3002 and
- 1 x KL4002

The arrangement of the bus terminals relative to the bus coupler is not relevant to the assignment of identifiers, only the bit-width of the bus terminals in the K bus and thus also in the process image is significant. The assignments always begin with the byte-oriented bus terminals, and the list of byte-oriented bus terminals is then followed by the bit-oriented digital bus terminals. The analog bus terminals are always marked as input/output. When assigning the addresses, you can leave out inputs or outputs which are not required in order to save addresses on the SPS.

N.B. different from the BK3100

Identifier for analog inputs = 208 (1 input word, module consistency)

Identifier for analog outputs = 224 (1 output word, module consistency)

The identifier 177 cannot be used.

Securing data consistency

The data transfer protocol of the Profibus ensures that each station's data is consistent. The consistency over the whole of the process image can be achieved by activating the operating modes "SYNC" and "FREEZ" in the masters.

Inconsistencies may arise due to the asynchronous access of the controlling CPU (usually SPS) to the data area of the PROFIBUS master. If you configure a "multi-byte signal" and module consistency in the configuration software COMWIN for the IM308-C the data consistency will automatically be secured. For other master units, please refer to the explanation in the manufacturer's documentation manuals.

Commonly used SPS standard units are the IM308-B and IM 308-C as Profibus DP masters, and the CP5431 as DP and FMS master.

You will find detailed information about the IM308-B in Siemens' manual Decentralized Peripherals System ET200, order no.: 6ES5 895-6SE11, with reference to data exchange with the Siemens S5. The manual explains the operation of the program ET200COM and Appendix B, "Access to decentralized peripherals" explains the rules which are used to ensure consistency.

The Windows program COMWIN, with extensive documentation, is available for the Profibus DP master unit IM308-C.

Appendix

Combined operation with PROFIBUS DP and PROFIBUS FMS

PROFIBUS is based on numerous recognized national and international standards. The protocol architecture follows the OSI (Open System Interconnection) reference model, which corresponds to the international standard ISO 7498. The architecture of PROFIBUS FMS and the PROFIBUS DP protocol is shown in the illustration "Protocol architecture of PROFIBUS FMS and PROFIBUS DP".

Both versions use the same protocol to access the bus (layer 2) and the same data transfer technology (layer 1).

Protocol architecture of PROFIBUS DP and PROFIBUS FMS

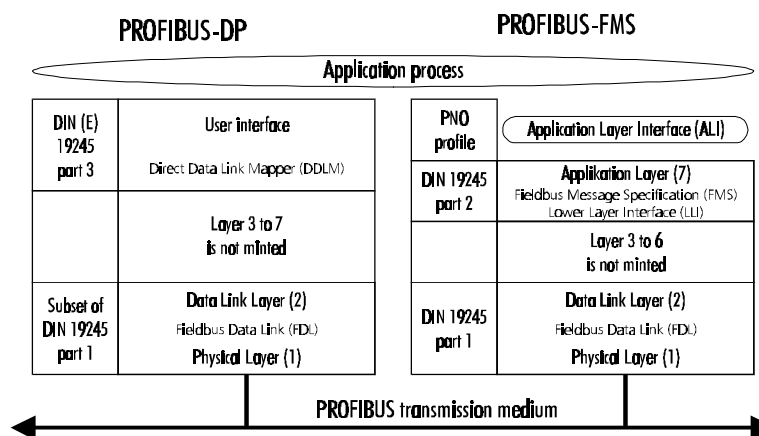

Layers 3 to 6 are not developed in PROFIBUS FMS. Those facilities of these layers that are necessary for this field of operation have been grouped together in the lower layer interface (LLI). The LLI is an element of layer 7.

The FMS (fieldbus message specification) includes the application protocol and provides a large number of powerful communication services. FMS is the interface to the application process. The FMS services are a subset of the MMS services (MMS, manufacturing message specification, ISO 9506) of the MAP protocol. The complex MMS services have been optimized to suit the requirements of fieldbus operations and supplemented by the addition of special functions for administering communications objects and network management functions.

Layers 3 to 7 are not developed in PROFIBUS DP. The application layer (7) is also omitted in order to achieve the necessary transfer rates. The Direct Data Link Mapper (DDL M) provides the user interface with convenient access to layer 2. The application functions which are available to the user, the system behavior, and the behavior of the various PROFIBUS DP device types, are all specified in the user interface.

One particular advantage of PROFIBUS is the ability to operate the components PROFIBUS FMS and PROFIBUS DP together on a single bus. For applications which are content with an increased system response time, the combined operation of PROFIBUS FMS and PROFIBUS DP bus couplers on a single bus is both possible and advantageous. It is even possible to operate both versions of the protocol on a single bus coupler simultaneously. These devices are then described as a "combislave". Using bus couplers as combislaves carries a number of advantages for the user:

It reduces the variety of different devices involved, because the identical device can be used flexibly, either for fast cyclic data transfer with PROFIBUS DP or with the more powerful PROFIBUS FMS services. For example, you can use the FMS services for parametrization when the installation is initially set up, when speed is not such a critical factor, and the fast DP functions for the cyclic transfer of user data in the operating phase of a controller. Such possible combinations offer manifold ways of utilizing these devices.

This combined operation is possible because both versions of the protocol use the same transfer and bus access procedures (layers 1/2). The various application functions are separated by the different service access points of layer 2. The bus coupler automatically recognizes the appropriate processing mode.

PROFIBUS FMS

PROFIBUS FMS makes it possible for automation devices to communicate with one another and with the intelligent field devices. The available functionality is more important here than a fast system response time. Many applications carry out predominantly acyclic data exchanges in response to requests from the application process. TRS bus couplers can operate both as DP slaves and FMS slaves.

PROFIBUS LAYER 7 (application layer)

Layer 7 of the ISO/OSI reference model provides useful communication services for the user. These application services permit efficient and open data transfer between application processes. The PROFIBUS application layer is specified in DIN 19 245 part 2 and consists of:

- Fieldbus Message Specification (FMS) and
- Lower Layer Interface (LLI).

FMS describes the communications objects, application services and the resulting models from the point of view of the communications partner. The LLI is used to adapt the application functions to the manifold features of the PROFIBUS layer 2.

*PROFIBUS
communication model*

An application process includes all the programs, resources and tasks which do not belong to any of the communication layers. The PROFIBUS communication model makes it possible to use communication relationships to combine distributed application processes into one overall process.

That part of an application process in a field device which is accessible via communications is described as a virtual field device (VFD).

In the PROFIBUS communication model, the mapping of the functions of the VFD onto the actual device is carried out by the application layer interface (ALI).

*Communications objects
and object directory (OD)*

All the communications objects belonging to a PROFIBUS subscriber are recorded in his local object directory. For simple devices, the object directory may be predefined. For complex devices, the object directory is planned and loaded into the device locally or remotely. The OD contains descriptions, structures and data types, and also the correlation of the internal device addresses of the communications objects with their identifier on the bus (index/name). The OD is made up as follows:

- Header (contains information about the structure of the OD).
- List of the static data types (list of the supported static data types)
- Static object directory (contains all the static communications objects)
- Dynamic list of variable lists (list of the currently known variable lists)
- Dynamic program list (list of the currently known programs)

The individual sections of the OD only have to be present if the device actually supports the corresponding functions.

Static communications objects are entered in the static object directory and may be predefined by the device manufacturer or be specified during the planning of the bus system. Communications in field applications uses principally static communications objects. PROFIBUS recognizes the following static communications objects:

- Simple Variable
- Array (series of simple variables of the same type)
- Record (series of simple variables of various types)
- Domain (data area)
- Event (a reported occurrence)

Dynamic communications objects are entered in the dynamic part of the OD (variable list directory / program invocation directory). They may be predefined and you can also use the application services to define, modify or delete them during the operating phase.

PROFIBUS supports the following dynamic communications objects:

- Program Invocation
- Variable List (series of simple variables, arrays or records)

Logical addressing is the preferred method for addressing communications objects in PROFIBUS. This accesses the communications objects by means of a short address, known as an index, which is a number of type Unsigned16. This permits efficient telegrams and reduces the protocol

overhead. An index is specified in the OD for each of the communications objects of a device. All PROFIBUS subscribers must support logical addressing.

PROFIBUS FMS also permits the following optional addressing methods for particular applications:

- Symbolic addressing using names: in this case the symbolic name of the communications object is transferred over the bus.
- Physical addressing: here you can access any desired physical memory address in the field devices by using the services Physical Read and Physical Write.

Each communications object can (optionally) be protected from unauthorized access. You can permit access to an object only with a specific password, or restrict it to a particular device group. You can specify the password and device group in the object directory separately for each individual object, and you can make an entry in the object directory to restrict the services which may be used to access the object (e.g. read-only access).

Sample arrangement of a process image in the bus coupler

The following example will illustrate the assignment of input/output channels to the process image. Our sample construction is to consist of the following bus terminal components:

For this configuration the bus coupler will create the list of assignments shown below

Position	Function component on the track
POS01	Bus coupler
POS02	2-channel digital input
POS03	2-channel digital input
POS04	2-channel digital input
POS05	2-channel digital input
POS06	2-channel digital input
POS07	2-channel digital output
POS08	2-channel digital output
POS09	2-channel digital output
POS10	2-channel analog input
POS11	2-channel analog output
POS12	2-channel analog output
POS13	2-channel analog input
POS14	Power input terminal
POS15	2-channel digital input
POS16	2-channel digital input
POS17	2-channel digital input
POS18	2-channel digital output
POS19	2-channel digital output
POS20	2-channel analog output
POS21	End terminal

(PROVISIONAL) Interbus and Profibus couplers currently support only 16-bit wide signal channels and the STATUS/CONTROL byte is not available. This means, for example, that an analog input terminal with 2 channels will appear in the process image with 2 x 16 bits. String communication is not included in the process image and is not supported. The images will also have a different representation as regards byte addresses and assignments. The bus coupler for the I/O Lightbus uses 4 bytes in the internal memory area of the bus coupler. From the release at the end of August, the Profibus coupler will parametrize a 3 byte channel so that the control/status byte is also available via the process image.

Area for byte-oriented data, analog outputs

Relative byte address	Bit position	Process image in the control unit	Position in the block
0, 1	none	O0, O1	POS11
2, 3	none	O2, O3	POS11
4, 5	none	O4, O5	POS12
6, 7	none	O6, O7	POS12
8, 9	none	O8, O9	POS19
10, 11	none	O10, O11	POS19

Area for bit-oriented data, digital outputs

Relative byte address	Bit position	Process image in the control unit	Position in the block
12	0	O12	POS07
12	1	O12	POS07
12	2	O12	POS08
12	3	O12	POS08
12	4	O12	POS09
12	5	O12	POS09
12	6	O12	POS18
12	7	O12	POS18
13	0	O13	POS19
13	1	O13	POS19

Area for byte-oriented data, analog inputs

Relative byte address	Bit position	Process image in the control unit	Position in the block
0, 1	none	I0, I1	POS10
2, 3	none	I2, I3	POS13

Area for bit-oriented data, digital inputs

Relative byte address	Bit position	Process image in the control unit	Position in the block
4	0	I4	POS01
4	1	I4	POS01
4	2	I4	POS02
4	3	I4	POS02
4	4	I4	POS03
4	5	I4	POS03
4	6	I4	POS04
4	7	I4	POS04
5	0	I5	POS05
5	1	I5	POS05
5	2	I5	POS06
5	3	I5	POS06
5	4	I5	POS15
5	5	I5	POS15
5	6	I5	POS16
5	7	I5	POS16

6	0	I6	POS17
6	1	I6	POS17

The items POS14 and POS21 are not relevant to data exchange and do not appear in the list. If a byte is not fully used, for example I8, the bus coupler pads its remaining bits with zeroes.

Overview of the distribution of the process image in the bus coupler:

*Output data
in the bus coupler*

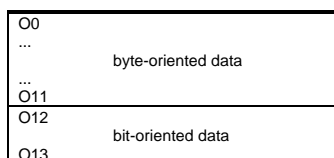

*Input data
in the bus coupler*

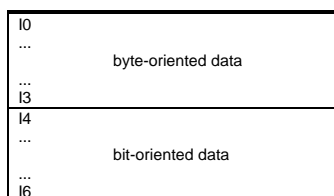

The base addresses I0 and O0 listed here are used as relative addresses or addresses in the bus coupler. If you have an appropriate superordinate Profibus system you can use the bus master to enter these addresses at any desired position in the process image of the control unit. You can use the configuration software of the master to assign the bytes to the addresses in the process image of the control unit.

Representation of analog signals in the process image

Three input bytes and three output bytes are required in the process image for each analog channel. Two bytes represent the value as an unsigned integer, i.e. 15 bits and sign. This data format is used regardless of the actual resolution. For example, with 12-bit resolution, the least significant four bits are meaningless. The low value byte has control and status functions. You can use the control byte to set up various operating modes. The lowest six bits can be used as the address bits for writing and reading a register set using string communications. A register set consists of 64 registers.

*I/O bytes of an analog
channel in the process
image*

Output byte 1	Output byte 0	Control byte
---------------	---------------	--------------

Input byte 1	Input byte 0	Status byte
--------------	--------------	-------------

*Significance of the
control/status bytes
for accessing
the register model*

BIT 7	0 = NORMAL MODE,	1 = CONTROL MODE
BIT 6	0 = READ,	1 = WRITE
BIT 5	Register address, MSB	
BIT 4	Register address	
BIT 3	Register address	
BIT 2	Register address	
BIT 1	Register address	
BIT 0	Register address, LSB	

Register set of an analog channel

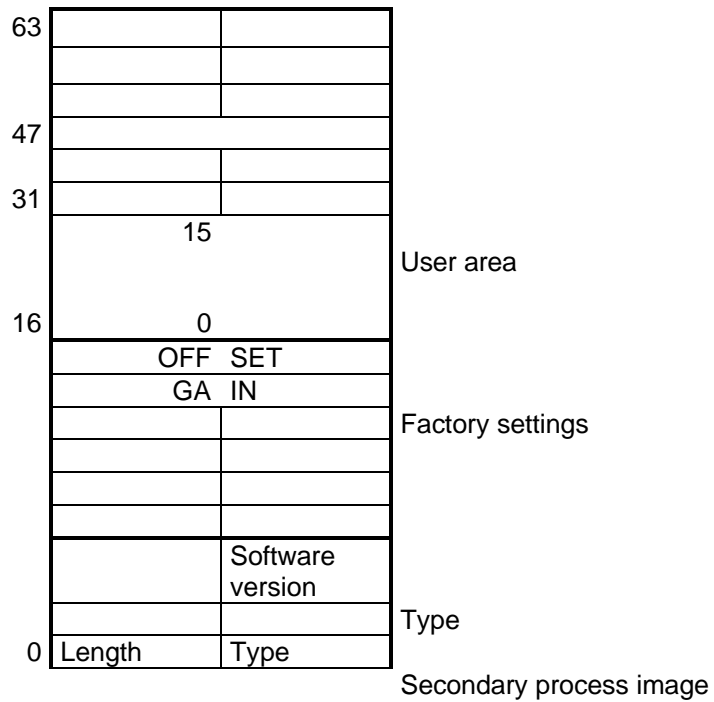

The significance of the registers and status bytes is explained in the data sheets for the corresponding bus terminals. The construction of the module is identical for bus terminals with more extensive signal processing.

PROFIBUS DP Setting parameters

The Set_Prm service enables you to transfer not only the parameters described in the DP standard, but also manufacturer-specific operating parameters (User_Prm_Data). These are characterized by the fact that they are transferred only once, when the connection from the master to the slave is set up. The User_Prm_Data for the bus couplers BK3000 and BK3100 is laid out as follows:

Byte no.	Description
Byte 0	0 (reserved for expansion)
Byte 1	0 (reserved for expansion)
Byte 2	0 (reserved for expansion)
Byte 3	0 (reserved for expansion)
Byte 4	0 (reserved for expansion)
Byte 5	Terminal 0 / Table 0 / Register 1 low Bit 0: 2-byte SPS interface on (1)/off (0) Bits 1-7: 0 (reserved for expansion)
Byte 6	Terminal 0 / Table 0 / Register 1 high 0 (reserved for expansion)
Byte 7	Terminal 0 / Table 0 / Register 2 low Bit 0: Auto Reset the terminal bus on errors, on (1)/off (0) Bit 1: Automatic terminal diagnostics, on (1)/off (0) Bits 2-7: 0 (reserved for expansion)
Byte 8	Terminal 0 / Table 0 / Register 2 high 0 (reserved for expansion)
Byte 9	Terminal 0 / Table 0 / Register 3 low Bit 0: 1 Bit 1: Programmed configuration (0)/Autoconfiguration (1) Bit 2: Evaluation of analog terminals: user data only(0)/complete (1) Bit 3: Data format for autoconfiguration: INTEL (0)/MOTOROLA(1) Bit 4: 0 (reserved for expansion) Bits 5,6: 1 Bit 7: 0 (reserved for expansion)
Byte 10	Terminal 0 / Table 0 / Register 3 high Bits 0,1: Response to fieldbus errors/Quit DP Data exchange/Clear_Data 0: Process data operation on the terminal bus is stopped 1: Outputs reset to 0 2: Outputs are unchanged Bits 2,3: Response to terminal bus errors 0: Quit DP Data exchange 1: Inputs reset to 0 2: Inputs are unchanged Bits 4-7: 0 (reserved for expansion)
Byte 11	Terminal 0 / Table 0 / Register 18 low Max. length of DP diagnostic data (possible values 16, 24, 32, 40, 48, 56, 64)
Byte 12	Terminal 0 / Table 0 / Register 18 high 0 (reserved for expansion)
Byte 13	Interval (in units of 10 ms) for refreshing automatic terminal diagnostics (in the range 10 - 255)
Byte 14	0 (reserved for expansion)

If no User_Prm_Data is transferred, the bus couplers will assume the default values shown in bold, or the value which was most recently programmed.

Configuration

You use the Chk_Cfg service to pass the configuration data which determines which process data is to be exchanged using the Data_Exchange service.

The state of bit 1 of register 3 in table 0 of the bus coupler determines whether autoconfiguration or programmed configuration is expected (see Setting parameters).

If bit 0 of register 1 in table 0 of the bus coupler is set, the first identifier in the configuration data indicates that the 2-byte SPS interface is switched on; this identifier is otherwise omitted:

ID	Description
0xB1	2-byte SPS interface

Auto configuration

Digital terminals

The data belonging to each of the digital input or output terminals is collected in a byte array in the order of their physical location. You can use the following identifiers for digital data:

ID	Description
0x1n	(n+1) bytes digital input
0x2n	(n+1) bytes digital output
0x3n	(n+1) bytes digital input and output

You can use these identifiers as desired, so that the total length of the input or output bytes always corresponds to the actual data length of the digital inputs and outputs (rounded up to a full byte).

Since the digital data is transferred after all the analog data, the digital identifiers must also be defined after all the analog identifiers.

Analog terminals

The analog terminals have 8-bit control or status data as well as user data on each channel. These terminals are classified as intelligent terminals and support register communication (8-bit control or status data, 16-bit I/O data for each channel). A particular code value in the control or status data determines whether the first 16 bits of the data are to be interpreted as I/O data for register communication.

You must define an identifier for each analog terminal or analog channel; their order depends on their physical location in the series.

There are also up to five different identifiers for each channel which are used for mapping it to the DP process data:

ID	Description
A:	Only the value is transmitted (no register communication is possible)
B:	The entire channel is transmitted (register communication is possible)
C:	The value, the control byte and the status byte are transmitted (no register communication is possible)
D:	The value and the status byte are transmitted (no register communication is possible)
E:	The value and the control byte are transmitted (no register communication is possible)

There are also up to two different identifiers for each terminal which are used for mapping it to the process data:

ID	Description
F:	Only the values are transmitted (up to 16 words) (no register communication is possible)
G:	All of the entire channels are transmitted (up to 16 words) (register communication is possible)

The master can thus decide separately for each analog channel how much data it should occupy in the process image.

Since there are also DP masters which write back the configuration that was read out from the slave (e.g. Siemens' CP5431), you can set up bit 2 of register 3 in table 0 of the bus coupler to specify whether the Cfg_Data of the Get_Cfg service should be set up according to A (Bit 2 = 0) or B (Bit 2 = 1) (see Setting parameters).

The DP configuration data for the various terminals looks like this:

Terminal	DP configuration data
KL3002, KL3012, KL3022, KL3032, KL3042, KL3052, KL3062, KL3202, KL3302	Channel 1 Channel 2 A: 0x50 0x50 B: 0xB2 0xB2 C: 0xC0 0x00 0x82 0xC0 0x00 0x82 D: 0x40 0x82 0x40 0x82 E: 0xC0 0x00 0x81 0xC0 0x00 0x81 Overall F: 0x51 G: 0xF2
KL3004, KL3014, KL3024, KL3034, KL3064	Channel 1 Channel 2 Channel 3 Channel 4 A: 0x50 0x50 0x50 0x50 B: 0xB2 0xB2 0xB2 0xB2 C: 0xC0 0x00 0x82 0xC0 0x00 0x82 0xC0 0x00 0x82 0xC0 0x00 0x82 D: 0x40 0x82 0x40 0x82 0x40 0x82 0x40 0x82 E: 0xC0 0x00 0x81 0xC0 0x00 0x81 0xC0 0x00 0x81 0xC0 0x00 0x81 Overall F: 0x53 G: 0xF5
KL4002, KL4012, KL4022, KL4032	Channel 1 Channel 2 A: 0x60 0x60 B: 0xB2 0xB2 C: 0xC0 0x82 0x00 0xC0 0x82 0x00 D: 0xC0 0x81 0x00 0xC0 0x81 0x00 E: 0x80 0x82 0x80 0x82 Overall F: 0x61 G: 0xF2
KL4004, KL4014, KL4024, KL4034	Channel 1 Channel 2 Channel 3 Channel 4 A: 0x60 0x60 0x60 0x60 B: 0xB2 0xB2 0xB2 0xB2 C: 0xC0 0x82 0x00 0xC0 0x82 0x00 0xC0 0x82 0x00 0xC0 0x82 0x00 D: 0xC0 0x81 0x00 0xC0 0x81 0x00 0xC0 0x81 0x00 0xC0 0x81 0x00 E: 0x80 0x82 0x80 0x82 0x80 0x82 0x80 0x82 Overall F: 0x63 G: 0xF5
KL1501	B: 0xB4 G: 0xF2
KL2502	B: 0xB2 G: 0xF2
KL5001	A: 0xD1 B: 0xB4 C: 0xC0 0x00 0x84 D: 0x40 0x84 E: 0xC0 0x00 0x83
KL5101	B: 0xB5 G: 0xF2
KL6001, KL6011, KL6021	B: 0xB5 G: 0xF2

Programmed configuration

You can use the configurator to place the terminals as desired into the local process image, and this image is then transferred by the Data_Exchange service.

The DP configuration data of the programmed configuration is located in table 70 of the bus coupler:

Table 70	Description
Register 0	Length of the DP configuration data (n, in the range 1-64)
Register 1-n	DP configuration data

This configuration data is also expected for the Chk_Cfg service and any other configuration data will be rejected.

Diagnostics

In addition to the fixed diagnostic data, you can use the Slave_Diag service to transfer other external diagnostic information. The external diagnostic data uses the same format as the device-specific diagnostics, in which each diagnostic message occupies 8 bytes. Since the device-specific diagnostic data is restricted to a total length of 63 bytes, this means that up to seven different diagnostic messages can be transferred. If more than seven different diagnostic messages have occurred, the diagnostic flag Ext_Diag_Overflow will be set in the fixed diagnostic data. The Ext_Diag_Data is laid out as follows:

Byte no.	Description
Byte 0:	Header of the device-specific diagnostics
Byte 1:	0 (reserved for expansion)
Bytes 2 - x:	8 bytes per diagnostic message (x: 9,17,25,33,41,49,57)

Diagnostic messages from the terminals

There is a diagnostic message for each terminal, which is laid out as follows:

Byte no.	Description
Byte 0	Terminal no. (1-64)
Byte 1	Channel no. (1-4)
Byte 2	SPS process image byte offset, low (0xFF: no assignment)
Byte 3	SPS process image byte offset, high (0xFF: no assignment)
Byte 4	SPS process image bit offset (0xFF: no assignment)
Byte 5	Status byte of terminal
Byte 6	Diagnostic register of terminal, low
Byte 7	Diagnostic register of terminal, high

SPS process image addresses will be entered only if the corresponding tables have been transferred (see tables 22-37 and 54-69 in the bus coupler)

Diagnostic messages from the bus coupler In addition to the diagnostic messages from the terminals, there are also two diagnostic messages from the bus coupler.

Byte no.	Description
Byte 0	0
Byte 1	0
Byte 2	Initialization error
Byte 3	Terminal bus error
Byte 4	Test of bus reset revealed errors
Byte 5	Incorrect terminal number on bus reset
Byte 6	Number of first terminal which is not supported
Byte 7	0

Byte no.	Description
Byte 0	255
Byte 1	0
Byte 2	UserPrmData error 0: No error 1: Could not transfer all the parameters to the EEPROM 2: Length of UserPrmData is wrong 3: Incorrect byte or word in UserPrmData
Byte 3	First incorrect byte or word in UserPrmData 0: byte 0 1: bytes 1,2 2: bytes 3,4 3: bytes 5,6 4: bytes 7,8 5: bytes 9,10 6: bytes 11,12
Byte 4	CfgData error 0: No error, 1: Not enough CfgData, 2: Incorrect byte in CfgData, 3: Terminal is not yet supported
Byte 5	First incorrect byte in CfgData (0 - 63)
Byte 6	0
Byte 7	0

Initialization errors	Description
Bit 0	Error on reading the EEPROM
Bit 1	Compile buffer is too small
Bit 2	Error on checking the programmed configuration
Bit 3	Error on reading out the terminal types on the terminal bus
Bit 4	Terminal is not supported
Bit 5	Too much configuration data
Bit 6	Too much output data (total output data of all terminals is too long)
Bit 7	Too much input data (total input data of all terminals is too long)

While there is an initialization error pending, the flag Stat_Diag will be set in the fixed diagnostic data, with the effect that you will not be able to execute a process data cycle on the terminal bus.

Terminal bus errors	Description
Bit 0	Too many errors on sending a command on the terminal bus (slave detected an error on comparing the command with the inverted command)
Bit 1	Too many timeouts on command execution (slave did not acknowledge command execution)
Bit 2	Too many errors on receiving input data (master detected an error on comparing the input data with the inverted input data)
Bit 3	Too many errors on transmitting the output data (slave detected an error on comparing the output data with the inverted output data)
Bit 4	Error on bus reset
Bit 5	Terminal bus error
Bit 6	
Bit 7	

Exchanging data

The process data is placed in the input and output data according to the transferred configuration; the digital data comes at the end of all the analog data.

The bus coupler BK 3000 supports up to 244 bytes of input or output data, the bus coupler BK 3100 supports 64 or 128 bytes depending on the setting in register 16 in table 0 of the bus coupler (see Other DP services). You can use bit 3 of register 3 in table 0 of the bus coupler to specify whether the user data should be inserted into the process image in INTEL format or MOTOROLA format (see Setting parameters). This enables you to map these values in such a way that the master will be able to access them as words or double words without having to swap over the individual bytes.

Siemens DP Master (IM 308B, IM 308C, CP5431)	
KL3002, KL3012, KL3022, KL3032, KL3042, KL3052, KL3062, KL3202, KL3302	A: MOTOROLA B: MOTOROLA C: MOTOROLA D: MOTOROLA E: MOTOROLA
KL3004, KL3014, KL3024, KL3034, KL3064 KL4002, KL4012, KL4022, KL4032	F: MOTOROLA G: MOTOROLA
KL4004, KL4014, KL4024, KL4034	
KL 1501	B: MOTOROLA G: MOTOROLA
KL 2502	B: MOTOROLA G: MOTOROLA

(continued) Siemens DP Master (IM 308B, IM 308C, CP5431)	
KL5001	A: MOTOROLA B: MOTOROLA C: MOTOROLA D: MOTOROLA E: MOTOROLA
KL 5101	B: MOTOROLA G: MOTOROLA
KL6001, KL6011, KL6021	B: no effect G: no effect

Bosch DP Master	
KL3002, KL3012, KL3022, KL3032, KL3042, KL3052, KL3062, KL3202, KL3302 KL3004, KL3014, KL3024, KL3034, KL3064 KL4002, KL4012, KL4022, KL4032 KL4004, KL4014, KL4024, KL4034	A: MOTOROLA B: INTEL C: INTEL D: INTEL E: INTEL F: MOTOROLA G: difficult to map
KL 1501	B: MOTOROLA G: difficult to map
KL 2502	B: MOTOROLA G: difficult to map
KL5001	A: difficult to map B: INTEL C: INTEL D: INTEL E: INTEL
KL 5101	B: INTEL G: difficult to map
KL6001, KL6011, KL6021	B: no effect G: difficult to map

Naturally, you can also use the contrary setting in each case, but this will mean that bytes will have to be swapped over in the DP master (or the SPS) before the data can be accessed as words or double words. The comment "difficult to map" signifies that, if the individual bytes are to be accessed singly, they will have to be remapped in the DP master whichever of the INTEL and MOTOROLA settings you specify.

Other DP services

Global_Control

You can use the Global_Control service to control both Sync and Freeze operation, the bus couplers support both of these. This also sends the Clear_Data command which has the effect specified in bits 8 and 9 of register 3 in table 0 of the bus coupler (see Setting parameters).

Set_Slave_Address

Changing the station address via the bus is not supported at present.