

BK-8100

Technical Documentation RS232 coupler

Please keep for further use !

Edition date/Rev. date: 30.11.1998
Document no./Rev. no.: TRS - V - BA - GB - 0106 - 00
Version: 1.1
File name: TRS-V-BA-GB-0106.DOC
Author: MÜJ

TRSystemtechnik GmbH
Eglishalde 6
D-78647 Trossingen
Germany
Tel. +49 - (0) 7425 / 228-0
Fax +49 - (0) 7425 / 228-34

Imprint

TRSystemtechnik GmbH

D-78647 Trossingen
Eglisshalde 6
Tel.: (+49) 07425/228-0
Fax: (+49) 07425/228-34

© Copyright 1998 TRSystemtechnik

Guarantee

In our ongoing efforts to improve our products, TRSystemtechnik reserve the right to alter the information contained in this document without prior notice.

Printing

This manual was edited using text formatting software on a DOS personal computer. The text was printed in *Arial*.

Fonts

Italics and **bold** type are used for the title of a document or to emphasize text passages.

Passages written in Courier show text which is visible on the display as well as software menu selections.

"< >" refers to keys on your computer keyboard (e.g. <RETURN>).

Note

Text following the "NOTE" symbol describes important features of the respective product.

Copyright Information ©

MS-DOS is a registered trademark of Microsoft Corporation.

Revision History

i

Note:

The cover of this document shows the current revision status and the corresponding date. Since each individual page has its own revision status and date in the footer, there may be different revision statuses within the document.

Document created:

30.11.1998

Revision	Date

Basic information

The TRS bus terminal system

<i>Up to 64 bus terminals</i>	The bus terminal system is the universal connecting link between a fieldbus system and the sensor/actor level. A unit consists of a bus coupler, which is the interface to the fieldbus, and up to 64 electronic terminals, of which the last is an end terminal. Terminals, each with two I/O channels, are available for any form of technical signal and can be combined as desired. The various types of terminal are all constructed in the same way, so that the planning costs are kept extremely low. The height and depth of the construction are calculated for compact terminal cabinets.
<i>each with 2 I/O channels for any form of signal</i>	Fieldbus technology makes it possible to use compact control architectures. The I/O level does not need to be taken right up to the control unit. Sensors and actors can be connected decentrally with minimal lengths of cable. You can position the control unit at any convenient location in the installation. Using an industrial PC as control unit makes it possible to implement the operating and monitoring element as part of the control hardware, so the control unit can be located on an operating desk, control point or similar. The bus terminals constitute the decentralized input/output level of the control unit in the switch cabinet and its subordinate terminal cabinets. As well as the sensor/actor level, the power unit of the equipment is also controlled via the bus system. The bus terminal replaces a conventional terminal as the cabling level in the switch cabinet; the switch cabinet can be made smaller.
<i>Decentralized wiring of the I/O level</i>	
<i>IPC as control unit</i>	
<i>Bus couplers for all current bus systems</i>	The TRS bus terminal system combines the advantages of a bus system with the functionality of compact terminals. Bus terminals can be used on all current bus systems and serve to reduce the diversity of parts in the control unit, while behaving like the conventional standard units for the relevant bus system and supporting the entire range of functionality of the bus system.
<i>Standard C rail assembly</i>	The simple and compact assembly on a standard C rail, and the direct cabling of actors and sensors without cross connections between the terminals, serve to standardize the installation, as does the uniformly designed labeling.
<i>Modularity</i>	The small size and great flexibility of the bus terminal system mean that you can use it anywhere that you could use a terminal and use any type of connection – analog, digital, serial or direct sensors.
<i>Display of channel status</i>	The modular construction of the terminal row, using bus terminals with various functions, limits the number of unused channels to at most one per function. Two channels to a terminal is the optimum solution for the number of unused channels and the cost per channel. The possibility of using power input terminals to provide separate power supplies also helps to minimize the number of unused channels.
<i>The K-bus</i>	The integrated light-emitting diodes close to the sensor/actor indicate the status of each channel.
<i>End terminal</i>	The K-bus is the path taken by data within the terminal row. The bus coupler carries the K bus through all the terminals by means of six contacts on the side walls of the terminals, and the end terminal terminates the K bus. The user does not need to know anything about the function of the K bus or the internal operation of terminals and bus couplers. There are

numerous software tools available which provide for convenient planning, configuration and operation.

Power input terminals for separately powered groups

Three power contacts pass the operating power to the following terminals. You can use power input terminals to subdivide the terminal row as desired into groups, each with a separate power supply. These power input terminals are not taken into account for addressing the terminals, you can insert them at any position along the terminal row. You can install up to 64 terminals on a terminal row, including power input terminals and the end terminal.

The principle of the bus terminal

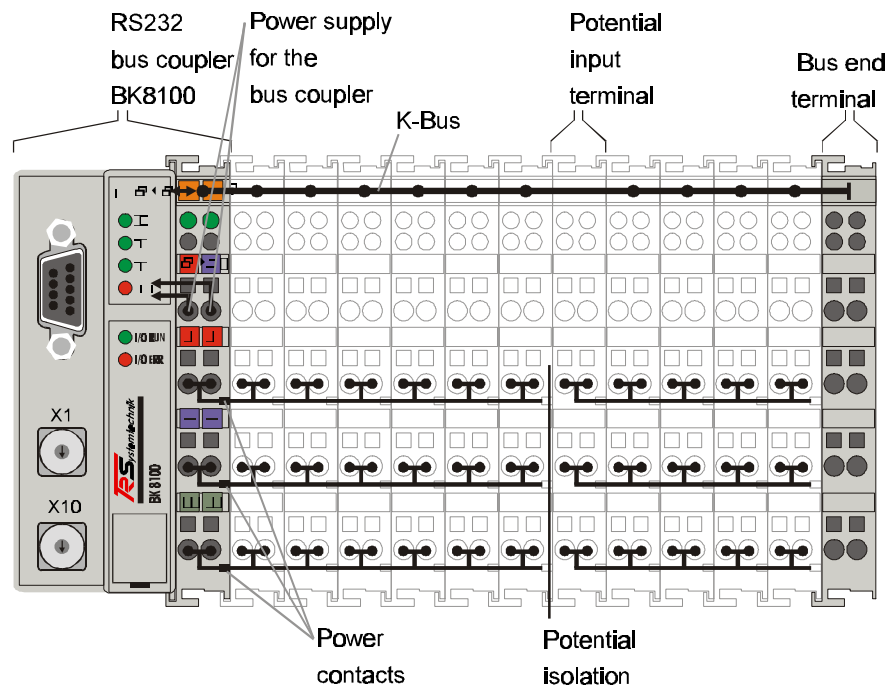

Bus couplers for various fieldbus systems

You can use a variety of bus couplers to attach the electronic terminal row quickly and easily to the various fieldbus systems, and you can also subsequently convert to a different fieldbus system. The bus coupler deals with all the necessary monitoring and control tasks for operating the attached bus terminals, indeed all the operation and configuration of the bus terminals is carried out via the bus coupler. The fieldbus, K bus and I/O level are electrically isolated.

If the exchange of data across the fieldbus is temporarily interrupted, logic states are preserved, digital outputs are cleared and analog outputs revert to a reset value which can be individually configured for each output when the equipment is set up.

The interfaces

There are six ways of making a connection to a bus coupler. These interfaces are designed as plug connections and spring terminals.

*The RS232 coupler
BK8100*

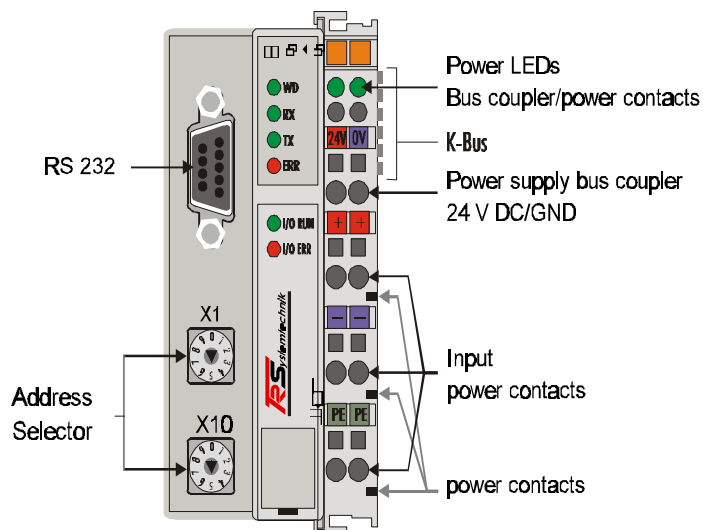

*24 V DC on the topmost
terminals*

Power supply

The bus couplers need an operating power of 24 V DC which is connected via the topmost spring terminals, labeled "24 V" and "0 V". This power supply serves not only the electronic components of the bus coupler but (via the K bus) also the bus terminals. The power supply of the bus coupler circuitry and that of the K-bus (Terminal bus) are electrically isolated from the voltage of the field level.

*Lower 3 terminal pairs for
power input*

Power supply to the power contacts

The six lower connections with spring terminals can be used to supply power to the peripherals. The spring terminals are connected in pairs to the power contacts. The power supply to the power contacts has no connection to the power supply of the bus couplers. The power input is designed to permit voltages up to 24 V. The pair-wise arrangement and the electrical connection between the feed terminal contacts makes it possible to loop through the wires connecting to different terminal points. The load on the power contact may not continuously exceed 10 A. The current capacity between two spring terminals is the same as the capacity of the connecting wires.

maximum 24 V

maximum 10 A

Power contacts

Spring contacts at the side

On the right-hand side face of the bus coupler are three spring contacts which are the power connections. The spring contacts are recessed in slots to prevent them from being touched. When a bus terminal is connected, the blade contacts on the left-hand side of the bus terminal are connected to the spring contacts. The slot and key guides at the top and bottom of the bus couplers and bus terminals ensure reliable location of the power contacts.

9 pole Sub-D female connector strip

RS 232 Connection

There is a recessed front surface on the left-hand side. A 9-pole Sub-D connector can be plugged in here. A detailed description of the RS232 interface can be found in a further part of this manual (chapter entitled 'The media: plugs and cable').

6 contacts at the side

K-bus contacts

The connections between the bus coupler and the bus terminals are effected by gold contacts at the right-hand side of the bus coupler. When the bus terminals are plugged together, these gold contacts automatically complete the connection to the bus terminals. The K bus is responsible for the power supply to the electronic components of the K bus in the bus terminals, and for the exchange of data between the bus coupler and the bus terminals. Part of the data exchange takes place via a ring structure within the K bus. Disengaging the K bus, for example by pulling on one the bus terminals, will break this circuit so that data can no longer be exchanged. However, there are mechanisms in place which enable the bus coupler to locate the interruption and report it.

3 supply groups:
 fieldbus
 K-bus
 peripheral level

Supply isolation

The bus couplers operate with three independent supplies. The input power supplies the electrically isolated K-bus circuitry in the bus coupler and the K-bus itself. The power supply is also used to generate the operating power for the fieldbus.

Note: All the bus terminals are electrically isolated from the K bus, so that the K-bus is completely electrically isolated.

Setting up the power levels in the bus terminal system

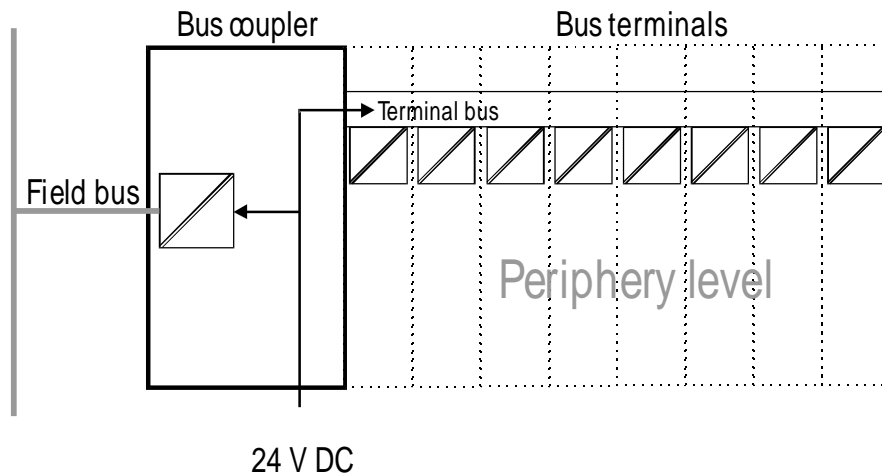

The operating modes of the bus coupler

When it is first switched on the bus coupler carries out a self-test to check the functions of its components and the communications of the K bus, and while this is going on the red I/O LED will flash. When the self-test has been completed successfully, the bus coupler will begin to test the attached bus terminals (the "bus terminal test") and read in the configuration from which it constructs an internal structure list, which is not accessible from outside. If an error occurs the bus coupler will enter the operating mode "STOP". If the start-up sequence is completed without errors the bus coupler will enter the mode "fieldbus start".

Start-up behavior of the bus coupler

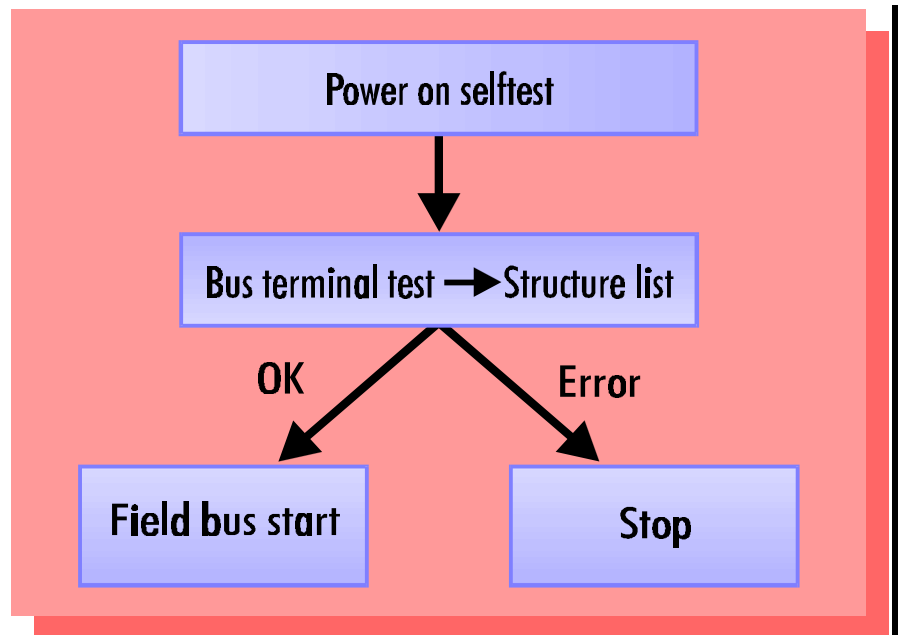

The bus coupler reports the error to the master by means of the Profibus diagnostics. Clearing the error returns the bus coupler to its normal operating mode.

Mechanical construction

The TRS bus terminal system is remarkable for its compact construction and high degree of modularity. When you design the installation you will need to plan for one bus coupler and some number of bus terminals. The dimensions of the bus couplers do not depend on the fieldbus system. If you use large plugs, for example like some of the bus plugs used for the Profibus, they may protrude above the overall height of the cabinet.

Dimensions of a bus coupler

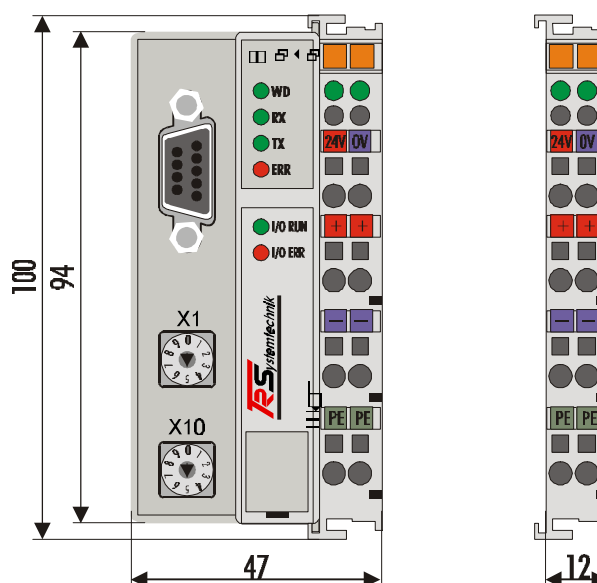

The overall width of the construction is the width of the bus coupler, including the bus end terminal, plus the width of the installed bus terminals. The bus terminals are 12 mm or 24 mm wide, depending on their function. Depending on the gauge of cables used the overall height of 68 mm may be overstepped by about 5 mm to 10 mm by the cables at the front.

Assembly and connections

It takes only a slight pressure to latch the bus coupler and the various bus terminals onto a supporting 35mm C rail and a locking mechanism then prevents the individual housings from being removed. You can remove them without effort if you first release the latching mechanism by pulling the orange tab. You should carry out work on the bus terminals and the bus coupler only while they are switched off: if you plug or unplug components while the power is on you may briefly provoke some undefined state (and, for instance, reset the bus coupler).

You can attach up to 64 bus terminals in series on the right-hand side of the bus coupler. When you assemble the components, make sure that you mount the housings so that each slot comes together with the corresponding key. You cannot make any functional connections merely by pushing the housings together along the supporting track. When they are correctly mounted there should be no appreciable gap between the adjacent housings.

The right-hand side of a bus coupler is mechanically similar to a bus terminal. There are eight connections on the top which can be used to connect to thick-wire or thin-wire lines. The connection terminals are spring loaded. You open a spring terminal by applying a slight pressure with a screwdriver or other pointed tool in the opening above the terminal and you can then insert the wire into the terminal without any obstruction. When you release the pressure the terminal will automatically close and hold the wire securely and permanently.

The connection between bus couplers and bus terminals is automatically effected by latching the components together. The K bus is responsible for passing data and power to the electronic components of the bus terminals. In the case of digital bus terminals, the field logic receives power via the power contacts. Latching the components together has the effect that the series of power contacts constitutes a continuous power track. Please refer to the circuit diagrams of the bus terminals: some bus terminals do not loop these power contacts through, or not completely (e.g. analog bus terminals or 4-channel digital bus terminals). Each power input terminal interrupts the series of power contacts and constitutes the beginning of a new track. The bus coupler can also be used to supply power to the power contacts.

Insulation test

The power contact labeled "PE" can be used as protective earth or ground. This contact stands proud for safety reasons and can carry short-circuit currents of up to 125A. Note that in the interests of electromagnetic compatibility the PE contacts are capacitively connected to the supporting track. This may lead to spurious results and even damage to the terminal when you test the insulation (e.g. insulation test for breakdown using a 230V mains supply to the PE line). You should therefore disconnect the PE line on the bus coupler while you carry out insulation tests. You can disconnect other power supply points for the duration of the test by drawing the power supply terminals out from the remaining row of terminals by at least 10 mm. If you do this, there will be no need to disconnect the PE connections.

PE power contacts

The protective earth power contact ("PE") may not be used for any other connections.

Electrical data

The electrical data of the RS 232 bus coupler is listed in this chapter. The bus coupler is set to a baud rate of 38400 baud. Addresses from 0 to 99 can be set by means of two address selectors on the coupler. The following table provides an overview of all data.

Technical data	BK 8100
Voltage supply	24 V DC (20 ...29 V DC)
Input current	70 mA + (total K-Bus current)/4 500 mA max.
Output current K-Bus	1750 mA max.
Number of bus terminals	64
Digital peripheral signals	256 inputs/outputs
Analog peripheral signals	128 Ein-/ Ausgänge
Maximum number of bytes	512 Byte I and 512 Byte O
Station adress	selectable up to 99 via DIP switches
Baud rate	38400 Baud
Power contact voltage	24 V DC / AC
Power contact current load	10 A
Dielectric strength	500 Veff (Power contact / supply voltage)
Weight approx.	170g
Operating temperature	0°C ... +55°C
Storage temperature	-20°C ... +85°C
Relative humidity	95%, no condensation
Vibrations/shock resistance	conforms to IEC 68-2-6 / IEC 68-2-27
EMC resistance burst / ESD	conforms to EN 50082 (ESD, Burst) / EN 50081
Installation position	any
Type of protection	IP20

Current consumption on the K-Bus

For operation of the K-bus electronics, the bus terminals require energy from the K-bus that is supplied by the bus coupler. Refer to the catalog or the corresponding data sheets of the bus terminals for details of the K-bus current consumption. In doing so, pay attention to the maximum output current of the bus coupler that is available for powering the bus terminals. Using a special power supply terminal (KL9400), power can be fed back into the K-bus at any chosen point. If you wish to use a power supply terminal, please contact TRS's technical support. .

The peripheral data in the process image

When the bus coupler is first switched on it determines the configuration of the attached input/output terminals and automatically assigns the physical slots of the input/output channels to the addresses in the process image.

The bus coupler sets up an internal list of assignments in which each of the input and output channels has a specific position in the process image. A distinction is made here between input and output and between bit-oriented (digital) and byte-oriented (analog, or complex) signal processing.

It also forms two groups, whereby one contains only inputs and the other only outputs. In each group, the byte-oriented channels take the lowest addresses, in ascending order, and these are then followed by the bit-oriented channels.

Digital signals (bit-oriented)

Digital signals are bit-oriented. This means that one bit of the process image is assigned to each digital channel. The bus coupler sets up a block of memory containing the current input bits and arranges to immediately write out the bits from a second block of memory which belongs to the output channels.

The precise assignment of the input and output channels to the process image of the control unit is explained in detail in the Appendix by means of an example.

Analog signals (byte-oriented)

The processing of analog signals is always byte-oriented and analog input and output values are stored in memory in a two-byte representation. The values are held as "SIGNED INTEGER" or "twos-complement". The digit "0" represents the input/output value "0V", "0mA" or "4mA". When you use the default settings, the maximum value of the input/output value is given by "7FFF" hex. Negative input/output values, such as -10V, are represented as "8000" hex and intermediate values are correspondingly proportional to one another. The full range of 15-bit resolution is not realized at every input/output level. If you have an actual resolution of 12 bits, the remaining three bits have no effect on output and are read as "0" on input. Each channel also possesses a control and status byte in the lowest value byte. If the control/status byte is mapped in the control unit has to be configured in the master configuration software. An analog channel is represented by 2 bytes user data in the process image.

Special signals and interface

A bus coupler supports bus terminals with additional interfaces, such as RS232, RS485, incremental encoder, etc.. These signals can be regarded in the same way as the analog signals described above. A 16-bit data width may not be sufficient for all such special signals; the bus coupler can support any data width.

Default assignment of inputs and outputs to the process image

When the bus coupler is first switched on it determines the number of attached bus terminals and sets up a list of assignments. This list distinguishes between analog channels and digital channels and between input and output; which are grouped separately. The assignments begin immediately to the left of the bus coupler. The software in the bus coupler creates the assignment list by collecting the entries for the individual channels one at a time, counting from left to right. These assignments distinguish four groups:

	Function type of the channel	Assignment level
1.	Analog outputs	byte-wise assignment
2.	Digital outputs	bit-wise assignment
3.	Analog inputs	byte-wise assignment
4.	Digital inputs	bit-wise assignment

Analog inputs/outputs are representative of other complex multi-byte signal bus terminals (RS232, SSI sensor interface, ...)

Overview of the subdivision of the process image in the bus coupler:

Output data in the bus coupler

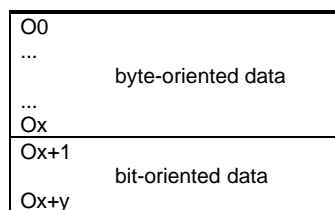

Input data in the bus coupler

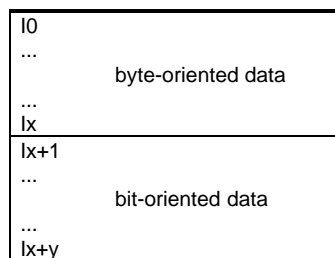

The way from I/Os to the process image in the application software

The bus coupler automatically assigns the I/Os of the terminals to the process image in the RS232 communication protocol. These allocations can be modified with the TRS KS2000 configuration software. Various mapping parameters (e.g. Motorola/Intel format) can be set in the bus coupler.

Data consistency

Data which contains no contradictions is said to be consistent. The following consistency is required here: 1. The high byte and low byte of an analog value (word consistency), 2. The control/status byte and the corresponding parameter word for accessing the register. The interaction of the peripherals with the control unit means that data can initially be guaranteed consistent only within an individual byte: the bits which make up a byte are read in together, or written out together. Byte-wise consistency is quite adequate for processing digital signals but is not sufficient for transferring values longer than eight bits, such as analog values. The various bus systems guarantee consistency to the required length. It is important to use the appropriate procedure for importing this consistent data from the master bus system to the control unit. The protocol for communication with the BK8100 always exchanges the coupler's complete process image, thus ensuring data consistency.

Processing complex signals

All byte-oriented signal channels such as RS232, RS485 and incremental encoder, can use byte lengths greater than two. Apart from the actual difference in length, the procedure is always comparable with that for analog signals.

Starting operation and diagnostics

When the bus coupler is first switched on it at once checks the attached configuration. A correct start-up procedure is indicated by the red LED "I/O ERR" going out. If this LED flashes, this indicates a fault somewhere in the terminals. You can determine the actual error code by observing the speed of flashing and number of flashes. This will enable you to clear the fault quickly.

The diagnostic LEDs

The bus coupler has two groups of LEDs to provide a status display. The top group of 4 LEDs indicates the status of the respective field bus. In the case of the BK8100, various data transfer communication states are displayed.

There are two further green LEDs on the top right side of the bus coupler to display the supply voltage. The left LED displays the bus coupler's 24 V power supply. The right LED signals the power supply to the Power contacts.

Local errors

Two LEDs, the "I/O LEDs", which are situated below the fieldbus status LEDs described above, are used to display the operating mode of the bus terminals and the connection to these bus terminals. The green LED lights up to indicate error-free operation, where "error-free" implies that communication with the fieldbus system is also operating correctly. The red LED flashes at two different rates to indicate a fault, whereby the specific error is encoded in the pattern of flashes, as follows.

Flashing code	
Fast flashing	Start of the error code
First slow sequence	Error code
Second slow sequence	Error argument

Error code	Error argument	Description
1 pulse	0	EEPROM checksum error
	1	In line code buffer overflow
	2	Unknown data type
2 pulses	0	Programmed configuration Invalid table entry/bus coupler
	n (n > 0)	Invalid table comparison (terminal n)
3 pulses	0	Terminal bus command error
4 pulses	0	Terminal bus data error
	n	Breakage after terminal n (0: coupler)
5 pulses	n	Terminal bus error during register communication with terminal n

The number of pulses (n) indicates the position of the last bus terminal before the error. Passive bus terminals such as an infeed terminal, for example, are not counted.

In the case of some errors, the bus coupler does not end the flashing sequence when the error is remedied. The bus coupler's operating state remains 'Stop'. The bus coupler can only be restarted by switching the supply voltage off and on or by means of a software reset. It is only

permitted to remove and to plug in bus terminals in the network after deactivation. The electronic circuitry of the bus terminals and of the bus coupler is largely protected against destruction, but malfunctions and damage cannot be ruled out when devices are plugged together while live. The occurrence of an error during ongoing operation does not immediately trigger output of the error code via the LEDs. The bus coupler must be requested to diagnose the bus terminals. The diagnostic request is generated after switching on or at the request of the master.

Communication errors

The top four LEDs show the operating states of RS232 communication. The two bottom LEDs indicate local communication between the bus coupler and bus terminals (as explained above).

There is nevertheless a relationship between the bottom green I/O RUN LED and RS232 communication when the bus coupler is switched to the 'Synchronous mode'. Then, the I/O RUN LED only lights up in connection with access to the internal K bus, i.e. the green I/O RUN LED does not light up until data transfer is commenced via the RS 232 connection. This means that the bus coupler must be accessed. This relationship does not apply in the bus coupler's default setting (Freerun). In this status, the I/O RUN LED is independent of the communication status of the serial communication link. The 4 communication LEDs indicate the status of RS 232 transfer. The operating states are indicated by the „WD,,, „RX,,, „TX,, and „ERROR,, LEDs.

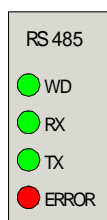

LED		Operating state
WD	Off	A watchdog timer overflow has occurred. No data is exchanged with the coupler during the set watchdog time.
RX	Flashing, flickering	Data is being received from the bus coupler via the interface.
TX	Flashing, lickering	Data is being received from the bus coupler via the serial interface.
ERROR	Lit	A data transfer error has occurred (e.g. parity error).

The green I/O LED lights up in connection with access to the internal K bus. However, the bus coupler queries the configuration of the bus terminals after switching on and does not exchange any data with the terminals. That is to say, the red I/O LED goes off after an error-free startup without the green I/O LED having to light up. Then, the green I/O LED does not light up until data transfer is commenced (see above).

RS 232 Coupler BK8100

System presentation

General

The BK8100 bus coupler enables the establishment of a simple peer-to-peer connection on the basis of an RS 232 transfer. The RS 232 coupler is usually connected to the PC via the serial interface.

Communication with the bus coupler is based on the master/slave principle, i.e. there is only one central station (the master), which controls access. The slave is only permitted to send at the master's request. The master must request (poll) the data of the slave (bus coupler) cyclically. At the same time, the station is assigned a station address (adjustable by rotary switch on the bus coupler) by way of which the master is able to address the respective station. Here, the master is always assigned the address 0, and the address 1-99 can be used by the slave.

During the exchange of data with the bus couplers, complete process images are always exchanged, i.e. the master sends the complete output data to the bus coupler and receives the input data of the bus terminals back from the coupler.

TRS KS8000: BKcom-OCX

A software driver for Windows95/NT is available for communication with the bus coupler. This „TRS KS8000: BKcom-OCX,, provides functionality with which a simple connection can be established from the PC's serial interface to the bus coupler. This OCX can be used by all programming languages that operate on the basis of the Microsoft Component Object Model (COM) specifications. You will find further explanations in the manual on the „KS8000: BKcom-OCX,,.

Master/Slave Communication between two bus couplers

It is possible to establish autonomous master/slave communication between two bus couplers. To do this, the master bus coupler must be set with the station address 0 and the slave bus coupler must be assigned the address 1. This enables a simple "complementary" exchange of data between two couplers. During such a data transfer, the master transfers its input data to the output terminals of the slave and outputs the slave's input data to its own output terminals. In this case, attention must be paid to ensuring that all data is complementary, i.e. the master must transfer the number of output data words to the slave that the slave possesses as input data words. The master must receive the same number of input data words as the number that it is capable of forwarding to the terminals as data output words.

Setting the station addresses

The station address is set by means of the rotary switches on the left side of the bus couplers. The address is set as a decimal number. The top rotary switch is the units power and the bottom one is the tens power of the address (example: station address 18: bottom rotary switch =1, top rotary switch = 8). The bus coupler must be reset (by brief interruption of the power supply or by software reset) to ensure that the rotary switch settings are stored by the bus coupler.

Address selector

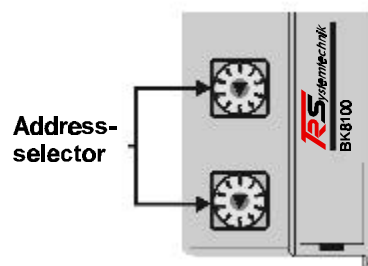

The media: plugs and cable

The cable is connected by means of a 9-pole D-sub connector on the left side of the bus coupler. A screened two-wire cable can be used provided the screen is connected to the signal ground (GND).

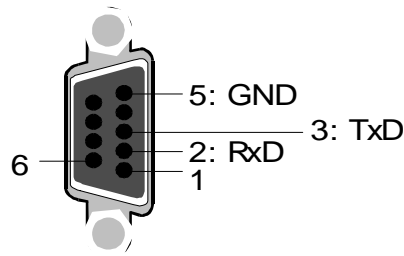

Point-to-point (peer-to-peer) connections can be established with the BK8100 bus couplers.

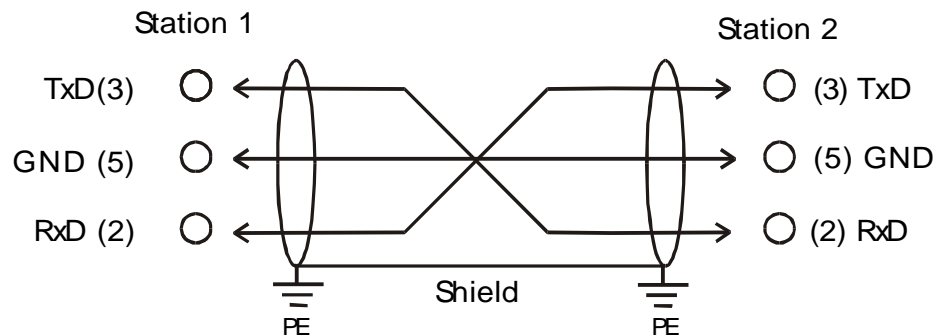

Fundamental characteristics of physical data transfer in accordance with RS 232

RS 232 data transfer	
Network topology	Peer-to-peer connection
Medium	Screened cable (2 x 2 x 0.32 mm ²).
Number of stations	2 stations in a peer-to-peer connection
Max. cable length	15 m
Data transfer rate	Adjustable by software up to 38.4 kbaud (9.4 k baud, 19.2 kBaud)
Connector	9-pole D-sub connection

Data communication

Data transfer protocol

Data communication with the bus coupler is realised by way of a simple data transfer protocol. During process data exchange with the BK8100, the complete process image is always transferred, i.e. when requested by the master the bus coupler receives the complete output data and then sends the current process input data in the response to the master. Data communication between the bus coupler and the individual bus terminals is realised via the "K bus". In the bus coupler's default setting, this access to the I/O signals of the terminals is asynchronous (the bus coupler is in the "free run" mode). Using the TRS KS2000 configuration software, it is very easy to set this mode to synchronous. In the synchronous mode, the bus coupler accesses the bus terminals synchronously with access by the master to the bus coupler.

The data packets are transferred in a fixed format as a binary string. The data frame is set permanently to 8 data bits, even parity and one stop bit (8 E 1). The baud rate is set by default to 38400 baud. As already mentioned, the station addresses are set by means of the two rotary switches on the bus coupler. When the address 0 is set, the BK8100 operates as the master and the slave bus coupler must be assigned the address 1.

Request

In the request, the master sends the process output data to be transferred to the slave. In the response, the slave sends its status and its process data inputs.

Description of request	Byte	Value range
Start identifier	0	'P' (0x50)
Number of process data output words	1	0 – 255
Message ident	2	0 – 255
Multipoint address	3	0 – 99
Process data output LOW Byte (optional)	4 + 2 x n (n = 0, 1, 2,..., 125)	0 – 255
Process data output HIGH Byte (optional)	5 + 2 x n	0 – 255
Checksum	6+2 x n + 1	0 – 255

The "start identifier" consists of one byte and identifies the start of a data packet. The "number of process data output words" specifies the size of the output process image of the addressed bus coupler in words. If the number of bytes of the process image is odd, it must be rounded up. A 0 must be entered if only the process input data of the bus coupler is to be read.

The "message ident" is any value that is returned by the recipient in the response string to enable the sender to assign received strings to the strings that have been sent.

The "multipoint address" specifies the recipient. The address must have a value unequal to 0 because 0 is the master address.

The "process data outputs" are entered as data words in INTEL format. The "checksum" is generated by adding up the contents of the individual bytes (complete request string without checksum byte). Any possible overflow is ignored.

Response

In its response, the bus coupler answers the request by the master.

Description of the response	Byte	Value range
Start identifier	0	'p' (0x70)
Number of process data input words	1	0 – 255
Message ident	2	0 – 255
Multipoint Adresse	3	0 – 99
Status	4	0 – 255
Process data input LOW Byte (optional)	5 + 2 x n (n = 0,1,2,..., 125)	0 – 255
Process data output HIGH Byte (optional)	6 + 2 x n	0 – 255
Checksum	6 + 2 x n + 1	0 – 255

The "start identifier" consists of one byte and identifies the start of a data packet. The "number of process data input words" specifies the size of the input process image in the bus coupler in words. If the number of bytes of the process image is odd, the bus coupler enters a dummy byte before the checksum.

The corresponding value of the request string is entered as the "message identity".

The "multipoint address" corresponds to the master address 0. The status byte contains information about the status of the bus coupler (see table). If available, the "process data inputs" are entered as data words in INTEL format.

The "checksum" is generated by adding up the contents of the individual bytes (complete response string without checksum byte). Any occurring overflow is ignored.

Status byte of the bus coupler

Bus coupler status byte	Error (Bit = 1)
Status.0	Terminal bus error: an error has occurred in data communication with the terminals
Status.1	Configuration error: see occur codes 1 and 2 (page 13)
Status.2	--
Status.3	--
Status.4	Invalid process data output length: the received number of process output words is unequal to the physically existing data length on the K bus.
Status.5	--
Status.6	--
Status.7	--

Example

The BK8100 is connected to a PC via the RS 232 interface. The address 1 has been set on the coupler. The coupler has been expanded with the following terminals (the mapped bits in the process image of the bus coupler are given in brackets):

- 3 x KL1002 (digital input terminal 3 x 2 input bits = 6 bits I)
- 2 x KL1114 (digital input terminal 2 x 4 input bits = 8 bits I)
- 1 x KL3002 (analog input terminal 2 x 16 bits I)
- 1 x KL9200 (potential infeed terminal 24 V DC, no I/O bits in the PI)
- 4 x KL2012 (digital output terminal 4 x 2 output bits = 8 bits O)
- 1 x KL4002 (analog output terminal 2 x 16 bits O A)
- 1 x KL9010 (end terminal, no I/O bits in PI)

The following table provides a list of the plugged-in terminals in their physical arrangement on the coupler with the affiliated mapped bits in the bus coupler's process image.

Position	Function module on the rail
POS00	BK8000
POS01	KL1002 (2 I)
POS02	KL1002 (2 I)
POS03	KL1002 (2 I)
POS04	KL1114 (4 I)
POS05	KL1114 (4 I)
POS06	KL3002 (2 x 16 I)
POS07	KL9200 (-)
POS08	KL2012 (2 O)
POS09	KL2012 (2 O)
POS10	KL2012 (2 O)
POS11	KL2012 (2 O)
POS12	KL4002 (2 x 16 O)
POS13	KL9010 (-)

Therefore, the process image on the bus coupler has the following breakdown:

Process image of the inputs:

Relative byte address in the bus coupler's PI	Bit position	Position in the block	Bus terminal
0, 1	None	POS06	KL3002, Channel 1
2, 3	None	POS06	KL3002, Channel 2
4	0	POS01	KL1002, Channel 1
4	1	POS01	KL1002, Channel 2
4	2	POS02	KL1002, Channel 1
4	3	POS02	KL1002, Channel 2
4	4	POS03	KL1002, Channel 1
4	5	POS03	KL1002, Channel 2
4	6	POS04	KL1114, Channel 1
4	7	POS04	KL1114, Channel 2
5	0	POS04	KL1114, Channel 3
5	1	POS04	KL1114, Channel 4
5	2	POS05	KL1114, Channel 1
5	3	POS05	KL1114, Channel 2
5	4	POS05	KL1114, Channel 3
5	5	POS05	KL1114, Channel 4

Process image of the outputs:

Relative byte address in the bus coupler's PIO	Bit position	Position in the block	Bus terminal
0, 1	None	POS12	KL4002, Channel 1
2, 3	None	POS12	KL4002, Channel 2
4	0	POS08	KL2012, Channel 1
4	1	POS08	KL2012, Channel 2
4	2	POS09	KL2012, Channel 1
4	3	POS09	KL2012, Channel 2
4	4	POS10	KL2012, Channel 1
4	5	POS10	KL2012, Channel 2
4	6	POS11	KL2012, Channel 1
4	7	POS11	KL2012, Channel 2

Request

The following data must be transferred in the request (output data to the coupler) from the master to the slave (BK8100):

Byte 1:	0x50 ('P')	Start identifier
Byte 2:	0x03	3 output data words
Byte 3:	0x12	Any selectable message ident
Byte 4:	0x01	Set bus coupler address
Byte 5:	0xXX	Data byte 0
Byte 6:	0xXX	Data byte 1
.	.	.
.	.	.
Byte 9:	0xXX	Data byte 4
Byte 10:	0xXX	Dummy byte
Byte 11:	0x??	Checksum calculated on the basis of the bytes (1-10)

Response

The bus coupler then sends the following response (input data of the bus coupler):

Byte 1:	0x70 ('p')	Start identifier
Byte 3:	0x05	3 input data words
Byte 4:	0x12	Returned message ident
Byte 5:	0x00	Master address 0
Byte 6:	0x??	Status byte
Byte 7:	0xXX	Data byte 0
Byte 8:	0xXX	Data byte 1
.	.	.
.	.	.
Byte 12:	0xXX	Data byte 5
Byte 13:	0x??	Checksum calculated on the basis of the bytes (1-12)

Watchdog

The bus coupler has a watchdog timer that is set by default to 1 s. The watchdog is triggered if no valid data exchange with the bus coupler has taken place after the expiry of this Watchdog time. The digital outputs are then all set to logical '0' and the analog terminals assume a user-defined status (by default, they are set to logical '0'). The input data is frozen at the last value. The bus coupler's watchdog time can be set using the TRS KS2000 configuration software.

Appendix

Sample arrangement of a process image in the bus coupler

The following example will illustrate the assignment of input/output channels to the process image. Our sample construction is to consist of the following bus terminal components:

For this configuration the bus coupler will create the list of assignments shown below

Position	Function component on the track
POS01	Bus coupler
POS02	2-channel digital input
POS03	2-channel digital input
POS04	2-channel digital input
POS05	2-channel digital input
POS06	2-channel digital input
POS07	2-channel digital output
POS08	2-channel digital output
POS09	2-channel digital output
POS10	2-channel analog input
POS11	2-channel analog output
POS12	2-channel analog output
POS13	2-channel analog input
POS14	Power input terminal
POS15	2-channel digital input
POS16	2-channel digital input
POS17	2-channel digital input
POS18	2-channel digital output
POS19	2-channel digital output
POS20	2-channel analog output
POS21	End terminal

In the default settings, RS485, RS232, CANopen, DevicNet, InterBus and Profibus couplers only map the analog input/output terminals in 16-bit wide signal channels. The CONTROL/STATUS byte is not available. That is to say, an analog terminal with two channels, for example, appears with two times 16 bits in the process image. The PLC interface is not integrated in the process image. Accordingly, the byte address and allocation mappings present themselves differently when CONTROL/STATUS is activated. For the function and system terminals, refer to the terminals' configuration instructions for details of the mapping in the bus coupler process image.

Area for byte-oriented data, analog outputs

Relative byte address	Bit position	Process image in the control unit	Position in the block
0, 1	none	O0, O1	POS11
2, 3	none	O2, O3	POS11
4, 5	none	O4, O5	POS12
6, 7	none	O6, O7	POS12
8, 9	none	O8, O9	POS20
10, 11	none	O10, O11	POS20

Area for bit-oriented data, digital outputs

Relative byte address	Bit position	Process image in the control unit	Position in the block
12	0	O12	POS07
12	1	O12	POS07
12	2	O12	POS08
12	3	O12	POS08
12	4	O12	POS09
12	5	O12	POS09
12	6	O12	POS18
12	7	O12	POS18
13	0	O13	POS19
13	1	O13	POS19

Area for byte-oriented data, analog inputs

Relative byte address	Bit position	Process image in the control unit	Position in the block
0, 1	none	I0, I1	POS10
2, 3	none	I2, I3	POS13

Area for bit-oriented data, digital inputs

Relative byte address	Bit position	Process image in the control unit	Position in the block
4	0	I4	POS02
4	1	I4	POS02
4	2	I4	POS03
4	3	I4	POS03
4	4	I4	POS04
4	5	I4	POS04
4	6	I4	POS05
4	7	I4	POS05
5	0	I5	POS06
5	1	I5	POS06
5	2	I5	POS15
5	3	I5	POS15
5	4	I5	POS16
5	5	I5	POS16
5	6	I5	POS17
5	7	I5	POS17

The items POS14 and POS21 are not relevant to data exchange and do not appear in the list. If a byte is not fully used, for example O13, the bus coupler pads its remaining bits with zeroes.

Overview of the distribution of the process image in the bus coupler:

Output data in the bus coupler

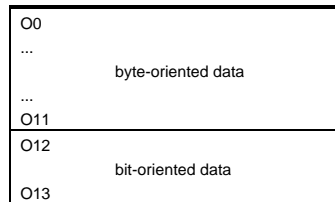

Input data in the bus coupler



The base addresses I0 and O0 listed here are handled as relative addresses or addresses in the bus coupler. A base peripheral address can be assigned to the base address of the bus coupler in the bus master software. All following addresses are automatically assigned the successive addresses depending on the length of the actual data words.

Representation of analog signals in the process image

Every analog channel consists of three input bytes and three output bytes but, in the standard case, one analog channel only occupies one data word in the process image. These two bytes represent the value as an unsigned integer, i.e. 15 bits with a sign. The data format is used independently of the actual resolution. For example: in the case of the resolution of 12 bits, the four least significant bits are irrelevant. Using the KS2000 configuration software, it is possible to insert the third byte into the process image for any chosen channels. The least significant byte has control and status functions. Various operating modes can be set with the control byte. The 6 least significant bytes can be used as addressing bits. Addressing serves to write and read the register set. The register set has 64 registers and permits setting of various operating parameters, for example selection of a thermocouple type or representation of the value in a different number format. For further information, refer to the corresponding documentation of the terminals.

I/O bytes of an analog channel in the process image

Output byte 1	Output byte 0	Control byte
---------------	---------------	--------------

Input byte 1	Input byte 0	Status byte
--------------	--------------	-------------

Significance of the control/status bytes for accessing the register model

BIT 7	0 = NORMAL MODE, 1 = CONTROL MODE
BIT 6	0 = READ, 1 = WRITE
BIT 5	Register address, MSB
BIT 4	Register address
BIT 3	Register address
BIT 2	Register address
BIT 1	Register address
BIT 0	Register address, LSB

Register set of an analog channel

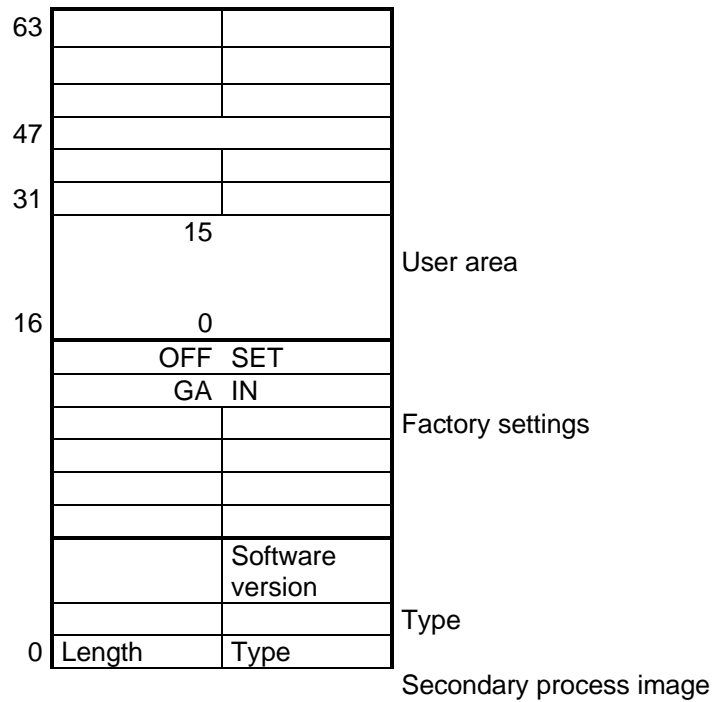

This representation is not available in the bus coupler's default setting. The KS2000 software is needed.

The meanings of the registers and of the status bytes are explained in the bus terminals' corresponding data sheets. The structure of the module is identical for all bus terminals featuring more extensive signal processing.