

MAI-4

Technical Documentation Analog Input Submodule

Please keep for further use !

Edition date/Rev. date: 16.12.1998
Document no./Rev. no.: TRS - V - BA - GB - 0031 - 00
Software version: 2.0
File name: TRS-V-BA-GB-0031.DOC
Author: MUH

TRSystemtechnik GmbH

Eglishalde 6

D-78647 Trossingen

Germany

Tel. +49 - (0) 7425 / 228-0

Fax +49 - (0) 7425 / 228-34

Imprint

TRSystemtechnik GmbH

D-78647 Trossingen
Eglisshalde 6
Tel.: (+49) 07425/228-0
Fax: (+49) 07425/228-34

© Copyright 1998 TRSystemtechnik

Guarantee

In our ongoing efforts to improve our products, TRSystemtechnik reserve the right to alter the information contained in this document without prior notice.

Printing

This manual was edited using text formatting software on a DOS personal computer. The text was printed in *Arial*.

Fonts

Italics and **bold** type are used for the title of a document or to emphasize text passages.

Passages written in *Courier* show text which is visible on the display as well as software menu selections.

"< >" refers to keys on your computer keyboard (e.g. <RETURN>).

Note

Text following the "NOTE" symbol describes important features of the respective product.

Copyright Information ©

MS-DOS is a registered trademark of Microsoft Corporation.

Revision History

i

Note:

The cover of this document shows the current revision status and the corresponding date. Since each individual page has its own revision status and date in the footer, there may be different revision statuses within the document.

Document created:

16.12.1998

Revision	Date

Table of contents

1 General 5

2 Setting options 6

 2.1 Position of the modular elements needed for the setting 6

 2.2 Meaning of bridges..... 6

 2.2.1 Setting of the voltage range 6

 2.2.2 Setting of the data format 7

 2.2.3 Current measurement 7

 2.2.4 Synchronical operation..... 7

3 Adjustment 8

4 Analog outputs 8

 4.1 Pin configuration of the analog outputs 8

5 Technical data of MAI-4..... 9

6 Pin configuration signal inputs 10

MAI-4



Eglshalde 6, 78647 Trossingen,
Germany Tel. +497425-228-0, Fax +497425-228-34

MAI-4 Analog Input Submodule

12-Bit or 16-Bit Resolution -10..+10V, 0.. +10V, 0..20 mA

1 General

The MAI-4 input module is a submodule for the FOX-20 basic module. It provides four analog inputs which are separated galvanically.

For operation in the II/O system, you can install up to four MAI-4s in the four slots of a FOX-20 basic module. This makes possible a maximum of 16 outputs per FOX-20. In addition, you can combine MAI-4s with different modules, e.g. digital outputs.

Two variants of the MAI-4 module can be supplied:

MAI-4-12	12-bit resolution (computational extended up to 13 bit)
MAI-4-16	16-bit resolution

In the 12-bit version the data bits are arranged in the data word in left justified form. So the data can always be fetched as 16-bit value.

Besides, the 4 analog inputs are layed over 100 ohm resistors on test sockets on the front panel. To these an external measuring system can be connected, for example when putting into operation.

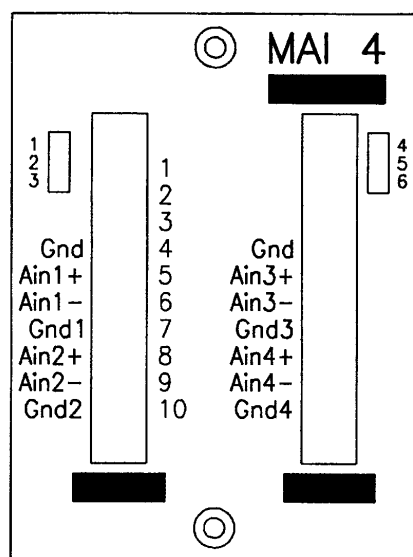

Figure 1: front panel MAI-4

2 Setting options

The MAI-4 is delivered in various preset versions. Regardless this fact, the module can be adjusted to the application by changing the bridges and adjusting elements described in the following.

2.1 Position of the modular elements needed for the setting

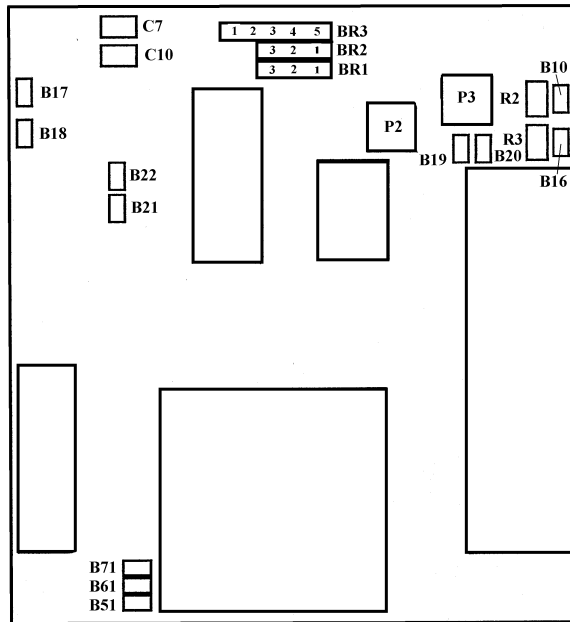

Figure 2: printed-circuit board underside

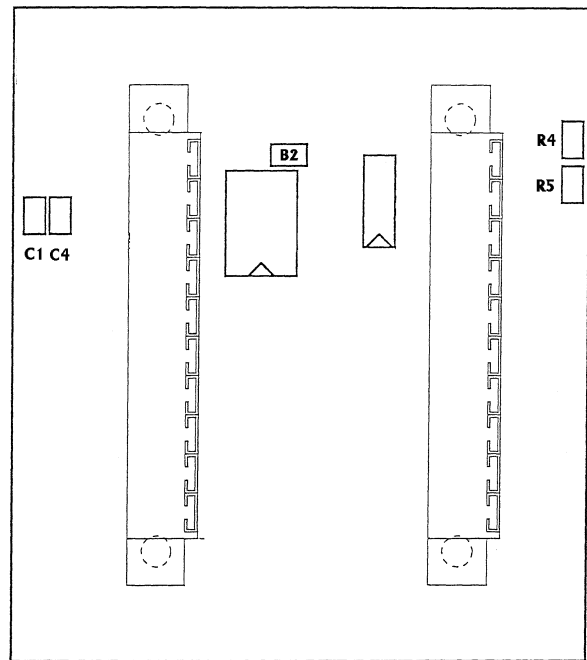

Figure 3: printed-circuit board top side

2.2 Meaning of bridges

Hint

The default settings are shaded dark in the tables.

2.2.1 Setting of the voltage range

With the bays BR1, BR2 und BR3 the module is adjusted to the measuring range $\pm 10V$ or $0..5V$.

range	BR1	BR2	BR3
$\pm 10V$	2-3 closed	2-3 closed	2-3, 4-5 closed
$+ 0..5V$	1-2 closed	1-2 closed	1-2, 3-4 closed

2.2.2 Setting of the data format

With the bridges B51 and B52, the format of the data transmission can be changed.

Bay BR1..BR3	B51	B52	Voltage range and corresponding data words				Resolution Version 12/16 bit
			-10V	0V	+5V	+10V	
+-10V	open	open	8000H-----	0000H-----	4000H-----	7FF8H	13 bit
			8000H-----	0000H-----	4000H-----	7FFFH	16 bit
0..5V	closed	closed		0000H-----	7FFCH		13 bit
				0000H-----	7FFFH		15 bit
0..5V	closed	open		0000H-----	FFF8H		13 bit
				0000H-----	FFFFH		16 bit

2.2.3 Current measurement

By closing a solder bridge, each input of the MAI-4 can be switched separately to current measurement. The standard version is equipped with measuring resistors of 500 ohm. As a result, the following current measurement ranges are possible:

Set voltage range	Current measurement range
+ - 10V	+ - 20mA
0..5V	0..10mA

The current measurement ranges can be changed by means of other measuring resistors.

The following bridges and resistors are assigned to the various channels:

	channel 1	channel 2	channel 3	channel 4
bridge	B10	B16	B17	B18
resistor	R2	R3	R4	R5

2.2.4 Synchronical operation

Caution:

The closing of the bridge described in the following is only allowed when using a special software in the basic module. In the normal version, this closed bridge results in a malfunction of the MAI-4.

In normal operating mode, the MAI-4 continuously scans the 4 analog channels and permanently provides the measured values. As this scanning occurs asynchronous to the field bus cycle, the measured values fetched from the field bus vary in age (max. 1 ms).

By closing bridge B71, the module can be switched to synchronical operation. In this operation mode, the module interrupts the scanning when all 4 channels are read. The reading of the measured value of channel 4 starts a new scanning cycle. As the module needs 200 µs for the recording of an analog value, the 4 channels can be read in sequence in a time interval of 250 µs. So the analog values are always new.

3 Adjustment

At the moment of delivery, the MAI-4 is adjusted, the corresponding potentiometers are secured with varnish. If a later adjustment should nevertheless be necessary, a short adjustment instruction follows now.

- Short-circuit Ain1+, Ain1- and GND1
- Adjust measured value with potentiometer P2 (offset) to 0.
- Apply at Ain1+ = max. measuring voltage (+10V or +5V), at Ain1- and at GND = 0V
- Adjust measured value with potentiometer P3 (gain) to positive maximum value.
- Apply at Ain1+ = min. measuring voltage (-10V or 0V), at Ain1- and at GND = 0V
- Check measured value on negative maximal value.

4 Analog outputs

In order to enable an external measuring system (for example an analog writer) to record the measured value, there are two 3-pole connectors with analog outputs on the front panel. The measuring signals are layed over 100 ohm on these outputs, but aren't buffered otherwise. That's why they may only be loaded with high impedance.

4.1 Pin configuration of the analog outputs

Left connector	
Pin	output
1	channel 1
2	channel 2
3	GND

Right connector	
Pin	output
4	channel 3
5	channel 4
6	GND

5 Technical data of MAI-4

Inputs	Four analog inputs, galvanically decoupled
Input Levels	Input voltage -10 V ... +10 V bipolar 0 ... 5 V unipolar or Input current -20 mA ... +20 mA 0 mA ... +10 mA Load 500 ohm
Decoupling	Submodule is galvanically separated to the basic module by optocoupler.
Resolution	MAI-4-12: 12-bit (13-bit); MAI-4-16: 16-bit
Scanning time	200 µs/channel = 800 µs/module
Supply Voltage	5 V DC (rom basic module)
Current Consumption	180 mA (without load and input currents)
Housing	Module with front panel is mounted in the FOX-10 using two screws.
Dimensions (W x H x D)	58 x 72 x 50 mm, weight 100 g
Temperature	Operation: ±0..+55° C Storage: -20..+70° C

6 Pin configuration signal inputs

Pin	Signal	I/O	Description
L-1			Not available
L-2			Not available
L-3			Not available
L-4	Gnd	Gnd	Ground
L-5	AI _{n1+}	In	Analog input, channel 1, positive
L-6	AI _{n1-}	In	Analog input, channel 1, negative
L-7	Gnd1	In	Ground for channel 1
L-8	AI _{n2+}	In	Analog input, channel 2, positive
L-9	AI _{n2-}	In	Analog input, channel 2, negative
L-10	Gnd2	In	Ground for channel 2
Pin	Signal	I/O	Description
R-1			Not available
R-2			Not available
R-3			Not available
R-4	Gnd	Gnd	Ground
R-5	AI _{n3+}	In	Analog input, channel 3, positive
R-6	AI _{n3-}	In	Analog input, channel 3, negative
R-7	Gnd3	In	Ground for channel 3
R-8	AI _{n4+}	In	Analog input, channel 4, positive
R-9	AI _{n4-}	In	Analog input, channel 4, negative
R-10	Gnd4	In	Ground for channel 4

Pin designations: L: left-hand row
M: middle row
R: right-hand row

Hint

The connected cables must be shielded!